

Rhinocoat™ High Temp Conduit

**A Class "A" Drainable, Dryable and Testable Conduit
For High Temperature Above or Below Ground Applications**

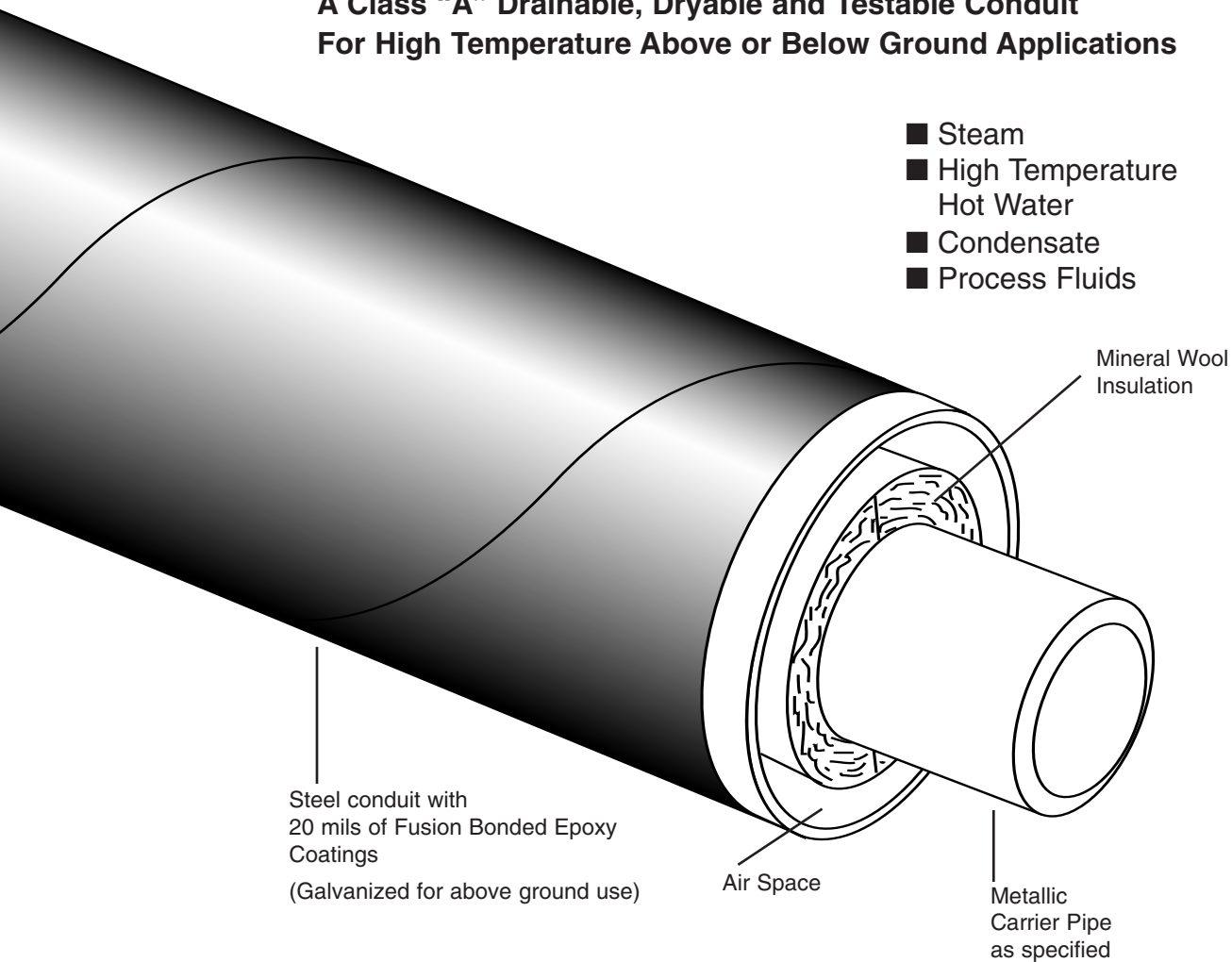

Rovanco's Rhinocoat Conduit is designed for piping systems suitable for up to 700° F applications. Mineral wool or calcium silicate insulation, and a durable 10 gauge minimum thickness steel conduit supplied in 40' lengths, means an economical, high-quality system.

Rovanco's conduit is provided with spooled out, part numbered, cut-to-length pieces factory manufactured to field dimensions. All elbows and tees are manufactured at Rovanco's plant.

The outer conduit is coated with nominal 20 mil thick "state-of-the-art" Fusion Bonded Epoxy Rhinocoat.

For above ground applications the steel casing has a hot dipped galvanized coating.

The conduit comes complete with joint insulation and steel sleeves the same thickness as the jacket with a shrink sleeve to make the installation completely watertight—the right product for applications of high pressure steam, condensate, hi-temp hot water, etc.

To find out more about Rovanco's conduit system, you can visit our factory, phone us (815)741-6700, fax us (815)741-4229, visit our web site at www.rovanco.com or e-mail us at marketing@rovanco.com.

CONDUIT GUIDE SPECIFICATION

Hi-Temperature Pre-insulated Conduit System for Steam, Hi-Temperature Hot Water, Condensate, Etc.

Carrier Pipe:

A53B Black Steel pipe, Seamless or ERW, in pre-cut lengths. Pipe 10" and smaller shall be Schedule 40. Pipe 12" and larger shall be .375 wall. (Schedule 80 shall be used for condensate lines.)

Other metallic pipes available.

Insulation:

Shall be sectional Mineral Wool with a K Factor of .31 at 200° F. Sectional insulation shall be banded on pipe with stainless steel banding on 18" centers. Insulation thickness shall be as specified.

Inner Pipe Supports:

All pipe shall be aligned and supported within the casing with galvanized steel supports spaced on centers approximately 10'0". The insulated inner pipe shall bear directly on the steel support. The support shall be designed as to permit drainage and free air passage. All pipe passing through supports shall be insulated. Concrete type pipe supports will not be allowed.

Outer Conduit Casing:

Outer casing shall be black steel. Casing up through 24" shall be 10 gauge. Casing 26" and larger shall be 6 gauge.

The interior surface shall be smooth to permit free moisture drainage and removability of the inner assembly. The outer casing shall be sized to provide an adequate annular space between the outer surface of the insulation material and the interior surface of the casing. The interior surface can be coated with epoxy for corrosion resistance. (optional)

The exterior surface will be coated with a two coat Fusion Bonded Epoxy system. The first coat will be green finish coat with a melting point of 500°F. No glasswrap or filler materials shall be used in the epoxy. All exterior conduit surfaces shall be shotblasted prior to the coating being applied. The Fusion Bonded Epoxy shall conform to these ASTM Standards:

ASTM D1763	Disclosure of properties of the epoxy sub-components
ASTM G17	Penetration test
ASTM D1044	Abrasion resistance
ASTM D2370	Tensile strength
ASTM G14	Impact tests
ASTM G8	Salt crock
ASTM D968	Abrasion tests
ASTM D1002	Shear strength and adhesion
ASTM D659	Compressive strength
ASTM D257	Volume resistivity
ASTM D1000	Electric strength
ASTM G53	Weathering
ASTM B117	Salt fog

The second layer will be compatible Fusion Bonded Epoxy coating that will provide mechanical protection to the first layer. The second layer of Fusion Bonded Epoxy will be applied no later than 5 seconds after the first layer has been applied so that it securely bonds to the first layer as both layers cure. The second layer must have an impact resistance of at least 160 lbs. per square inch as per ASTM G14-72. The Fusion Bonded Epoxy coating will be applied in a total thickness of no less than 20 mils. The coating system will be equal to Rovanco Piping Systems—Rhinocoat™. No asphalt, coal tar coating, FRP casing or any other type will be allowed.

Outer conduit casing closures shall consist of 10 gauge steel suitably rustproofed and in cylindrical form with a single horizontal split and shall be field welded over adjacent units. After tests all exposed closures shall be covered in the

field with a polyethylene heat shrink material with a minimum thickness of 60 mils.

Expansion loops and Els:

Expansion loops or expansion elbows shall be furnished and enclosed in the same type of casing as those furnished for the standard section of the piping system. They will be of a size to permit the inner pipe or pipes to move without damage to the insulation material. All expansion loops or expansion elbows shall be pre-fabricated and shipped to the job site in as few pieces as possible (manufacturers' recommendations to govern). All inner pipe loops and expansion bends shall be cold sprung in the field by the contractor as required.

Weld Fittings:

All changes in direction shall be made with bent or weld fittings. Where tee branches are smaller than the mains they join, weld-o-lets may be used. All weld fittings shall be long radius and shall be the same wall thickness as adjacent piping.

Anchors:

Anchors shall be pre-fabricated onto the piping units and shall be equipped with drainage and vent openings at the top and bottom of the anchor plate. Anchor plates shall be made of 1/2" steel plate.

End Seals and Gland Seals:

Terminal ends of conduits inside manholes, pits, or building walls shall be equipped with end seals consisting of a steel bulkhead plate welded to the pipe conduit. Where there is no anchor within five feet of a terminal end, conduits shall be equipped with gland seals consisting of a packed stuffing box and gland follower mounted on a steel plate welded to end of conduit.

End seals or gland seals shall be made of 1/2" steel plate with drain and vent openings located diametrically opposite on the vertical center line of the mounting plate and shall be shipped to the job site with plugs in place. Terminate all conduits 2 inches beyond the inside face of building walls to protect any exposed piping insulation from damp wall condensation.

Field Tests:

The inner pipes of this system shall be tested hydrostatically to 1 1/2 times the working pressure of the line. If a leak is found, it shall be repaired and the test repeated. The outer casing shall be tested with air at 15 psig and a soap solution shall be applied to the field joints to locate leaks. If leaks occur, they shall be repaired and the test repeated. After approved by test, all field joints shall be coated by the contractor. Before backfilling, the contractor shall test the conduit coating with an electric holiday detector. Any breaks in the coating system will be repaired and the test repeated by the contractor.

Backfill:

Should be tamped compactly in place so as to assure a stable surface. No rock should be used in the first foot of backfill. 24", top of pipe to grade, of compacted fill shall meet H-20 Highway Loading.

Installation:

The installation shall be made in accordance with plans and specifications, and manufacturers' installation instructions. Pre-insulator will provide a field service instructor on site to train the contractor in all phases of installation.

Approved Vendors:

Rhinocoat Conduit System by Rovanco, Joliet, Illinois, or approved equal. Any alternate supplier must submit their technical data to the engineer ten days prior to bid date to be approved in writing as an equal.

Copyright 1999 - Rovanco's products are covered by various U.S. patents. Rovanco & Insul-8 are federally registered trademarks.

Contact Your Rovanco® Representative

Rovanco

20535 S.E. Frontage Road
Joliet, Illinois 60431
(815) 741-6700
FAX (815) 741-4229