

# Rhinoflex<sup>®</sup> by Rovanco<sup>®</sup>

**FLEXIBLE PRE-INSULATED PIPING**

**ISO 9001:2015  
CERTIFIED COMPANY**

**PRI Registrar**  
PERFORMANCE REVIEW INSTITUTE

*The right product  
for the distribution  
of hot and cold fluids  
from -20° to 230°F\**

*Proudly Made in the U.S.A.*

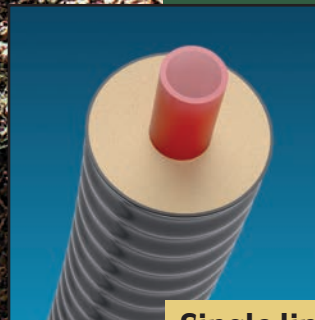

## **Single line Rhinoflex**

Available from 3/4" thru 5 1/2" with  
PEX-A Carrier Pipe and 1 1/2" thru  
4" with HDPE Pipe.

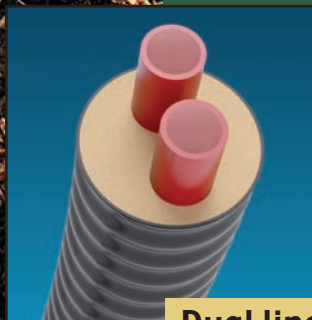

## **Dual line Rhinoflex**

Available from 1" thru 2 1/2" with  
PEX-A Carrier Pipe.



**Rovanco Piping Systems, Inc.**

**Rhinoflex** pre-insulated PEX-A and Polyethylene comes in the longest lengths available from any supplier of flexible pre-insulated piping. The charts provide dimensional data to allow the user to select the right Rhinoflex piping system for their needs. You can rely on Rovanco's "Thousands of Miles" of experience on hundreds of thousands of piping systems worldwide to help you select the right product for your piping systems! Rhinoflex is available with a PEX-A or HDPE carrier pipe.

There are more than 2,000 miles of flexible pre-insulated pipe with PEX-A or HDPE carrier pipe installed in the U.S. and more than 40,000 miles installed worldwide over a 35 year period!

Flexible pre-insulated piping has taken over the market for 6" and smaller pre-insulated pipe because it is a high quality product and it has the lowest installed cost of any pre-insulated pipe. The long lengths of flexible pre-insulated Rhinoflex result in few or no underground joints and up to 60% less labor resulting in an installed cost savings of 25 to 40%!



*Coils can be handled easily by 2 people.*



*Rhinoflex can be pulled through road sleeves up to 1,000 ft or directionally bored under roadways, walkways, driveways, streams and ponds! If installed with pipe weights, it can be laid directly in a pond, lake, river or stream!*



*Rhinoflex can easily be cut to length with just a hacksaw. No special tools or equipment are required to install. Rovanco provides complete installation kits, accessory materials, installation instructions. No special training or skills are required.*

### **Carrier Pipe**

For **hot service**, **PEX-A** is the highest quality crosslinked polyethylene pipe available with an oxygen diffusion barrier. NSF approved for domestic use.

For **cold service**, high density SDR-11 **polyethylene** carrier pipe is suitable for temperatures 140°F down to -20°F. Can be butt fused or electrofusion welded.

### **Insulation**

The high thermal efficiency of **flexible urethane** foam allows for a **smaller** outer jacket size than some competitors, and **lower heat losses**.

### **Outer Jacket**

The polyethylene outer jacket is **the heaviest available** in the industry and **corrugated** to be **flexible**. It is "**Rhino tough**", providing the ultimate in long term protection.



*Rhinoflex flexible pre-insulated pipe easily follows the route and contour of the trench.*

Since Rhinoflex is available in lengths of up to 2,500 feet with no field joints, there is no need to over excavate or put workmen into the trench to join, insulate, and seal pipe joints.

No welding, brazing or soldering in the trench. No need to worry about expansion and contraction means no concrete thrust blocks!

The smooth inner surface of the PEX-A and HDPE pipe, few if any coupling joints, and virtual elimination of fittings for changes in routing ensures even flow of the fluids and reduced pressure drops throughout the systems.

Joining Rhinoflex is quick and sure. Only the highest quality fittings are used to ensure leak proof joints for the life of the system.

**Rhinoflex** is built to take the rough handling experienced at the job site. The components are all flexible, non-corrosive and tough!



*Couplings are rated at 200 PSI – a higher pressure than the pipe! Rovanco carries male NPT fittings, sweat fittings, weld end fittings, flange fittings and Vic Groove fittings.*

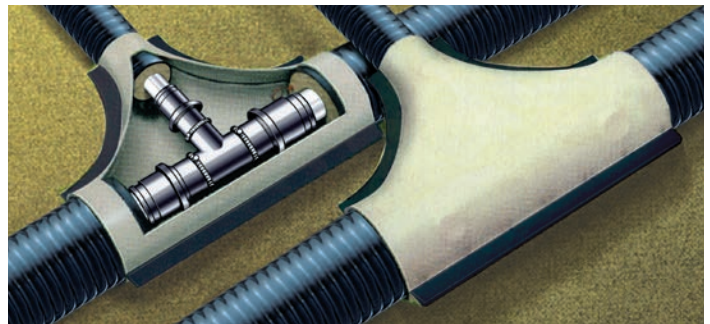

*The field insulation of tees and fittings is quick and easy. The plastic fitting covers are designed to be water tight at a 10 ft head of water. Insulation provided by Rovanco.*

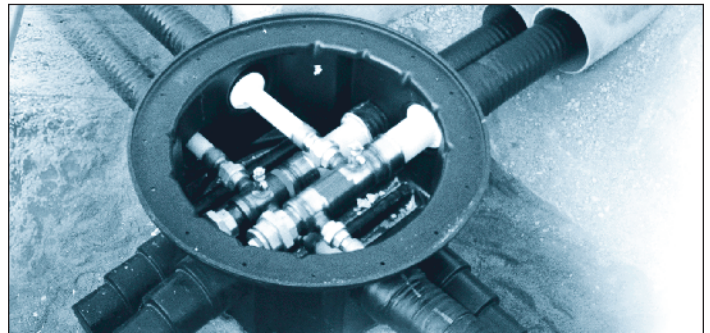

*Valving and branches can be accomplished in Rhinoflex manholes, custom designed to meet your system's requirements!*

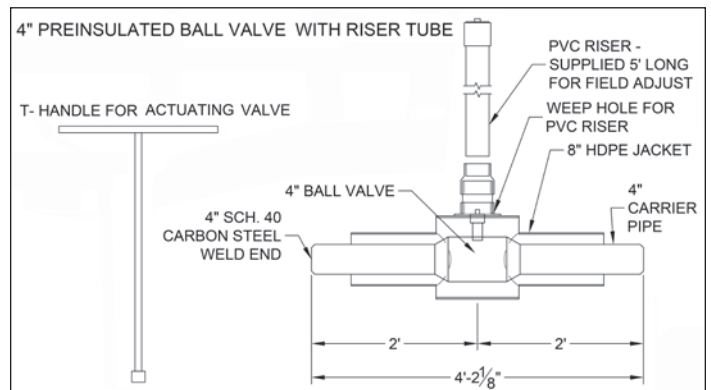
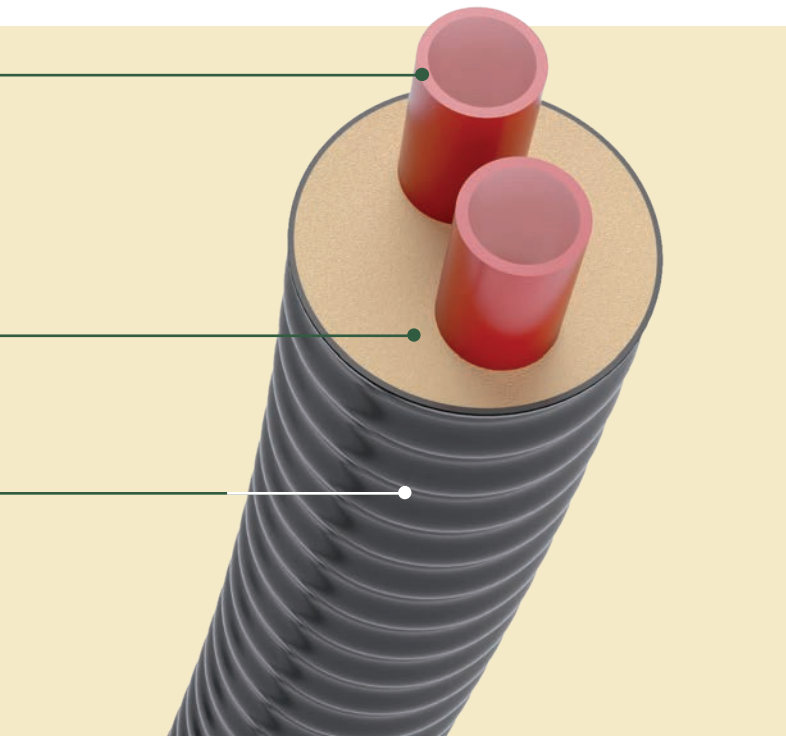

### Rhinoflex® Guide Spec.

Rhinoflex Flexible PEX Pipe for Hot Fluids up to 230°F\*.  
Rhinoflex Flexible HDPE Pipe for Cold Fluids to 140°F.

The pre-insulated piping system must be of a flexible design, and all components of carrier pipe, insulation, and jacket must be able to expand and contract as a unit without overstressing or adversely affecting any of the materials. The pipe, insulation, and jacket will all be made of materials that will not corrode. The insulation shall completely fill the annular space between the service pipe and jacket and shall be completely bonded to both. The insulation must be polyurethane. Systems using open-cell insulation, polyethylene insulation, PEX insulation, or any non-bonded system, or partial-bonded system design shall not be allowed. The system will be designed to be installed in a manner that will not require expansion loops or compensators of any type. The system will be installed with the fewest number of underground joints possible. The piping system supplier will be responsible for the overall design of the expansion and contraction compensation. The system will be supplied complete with coupling fittings, insulation kits, and termination fittings all supplied by the piping system supplier. All products must be manufactured to ISO 9002 standards.

**PEX Carrier Pipe** Cross-linked PEX-A pipe with EVOH (oxygen barrier Engel Method). NSF 61 certified. ASTM F876 and F877 for all pipes 3/4" - 2". 204°F maximum, 230°F intermittent. Pex-B and Pex-C products not allowed.

**HDPE Carrier Pipe** SDR11 High Density Polyethylene pipe suitable for temperatures up to 140°F at 80 psi.

**Insulation** All insulation materials will be supplied by the system manufacturer and will be polyurethane closed cell insulation with a K-Factor of .149. The insulation will be furnished in the thicknesses as shown in Charts 1, 2 & 3 for the respective carrier pipe sizes.

**Jacket Material** The outer protective jacket shall be corrugated seamless polyethylene completely encompassing and protecting the insulation from moisture and damage, designed for H-20 loading at a burial depth of 2 foot minimum. The jacket will be provided in diameter and thickness as shown in Charts 1, 2 & 3.

**Fittings** All fittings and connections will be either brass, copper, steel or electro-fusion fittings. They will be installed in accordance with the detailed installation instructions. All buried fittings and couplings will be insulated and sealed per the system supplier's instruction. All fittings for potable to be ASTM Approved.

**End Seals** All direct buried ends of insulated pipe with exposed insulation will be sealed with watertight polyethylene end seals.

**Manholes** The contractor has the option to supply field built manholes or factory supplied polyethylene or coated steel manholes. If the system supplier is providing the factory engineered manholes, they will be installed per the supplier's instructions.

**Field Tests** All carrier pipe systems should be hydrostatically tested at 1-1/2 times the operating pressure prior to burial or 100 psi.

**Backfill** A minimum of 4" of sand needs to surround Rhinoflex piping on all sides in the trench. Rhinoflex is suitable for H20 loading from 24" under road bed.

**Supplier Assistance** At customer's request, system supplier will provide a qualified field service technician on-site to properly train the installing personnel in all phases of installation.

**Approved Vendors** Rhinoflex, as supplied by Rovanco, Joliet, Illinois or approved equal. Any alternate supplier must submit their technical data to the engineer 20 days prior to bid date to be approved in writing as an equal.

**Warranty** Rovanco does not approve of the practice of installing pipe and fittings and backfilling the pipe before testing. Rovanco will not allow or pay claims for charges which arise in locating and digging up leaks regardless of cause. Rovanco only suggests pressure testing pipe with water, using any other method will void warranty.

## Rhinoflex Single Crosslinked Polyethylene • Chart 1

### Standard Products • Pre-Insulated PEX-A Pipes

Nominal Pipe Size Inches	Carrier Pipe Size mm	Carrier Pipe Type	Carrier I.D.	Nominal Insulation Thickness	PE Jacket O.D.	Jacket Thickness	Bending Radius	Heat Loss (Btu/hr/ft)			Wt lb/ft
								dt 30	dt 100	dt 150	
0.75"	ASTM	PEX	0.677"	1.00"	3.07	0.08	2'5"	3.38	11.56	16.90	0.08
1.00"	ASTM	PEX	0.875"	0.91"	3.07	0.08	2'5"	3.38	11.56	16.90	0.08
1.25"	ASTM	PEX	1.07"	0.80"	3.07	0.08	2'5"	3.53	11.76	17.64	0.88
1.50"	ASTM	PEX	1.263"	1.00"	3.66	0.09	3'0"	3.63	12.10	18.14	1.26
2.00"	ASTM	PEX	1.653"	1.13"	4.45	0.09	3'0"	4.14	13.81	20.17	1.45
2/2.5"	63 mm	PEX	2.035"	1.28"	5.03	0.10	3'3"	4.40	14.71	21.31	1.75
2.50"	75 mm	PEX	2.431"	1.34"	5.63	0.12	3'5"	4.50	15.00	22.50	2.28
3.00"	90 mm	PEX	2.915"	1.44"	6.42	0.13	4'0"	4.88	16.27	24.40	3.06
4.00"	110 mm	PEX	3.563"	1.05"	6.42	0.13	4'0"	7.27	24.22	36.33	3.82
5.00"	125 mm	PEX	4.047"	1.05"	7.20	0.13	4'5"	8.85	27.76	39.84	4.85
5.50"	140 mm	PEX	4.51"	1.22"	8.00	0.13	4'9"	10.98	29.84	42.64	5.85

## Rhinoflex Dual Crosslinked Polyethylene • Chart 2

### Standard Products • Pre-Insulated Twin PEX-A Pipes

Nominal Pipe Size Inches	Carrier Pipe Size mm	Carrier Pipe Type	Carrier I.D.	Nominal Insulation Thickness	PE Jacket O.D.	Jacket Thickness	Bending Radius	Heat Loss (Btu/hr/ft)			Wt lb/ft
								dt 30	dt 100	dt 150	
1.00"	ASTM	PEX	0.875"	1.70"	4.45	0.09	3'3"	3.97	16.59	22.42	1.50
1.25"	ASTM	PEX	1.07"	1.20"	4.45	0.10	3'3"	4.48	17.84	23.50	1.70
1.50"	ASTM	PEX	1.263"	1.25"	6.42	0.13	4'0"	5.46	18.08	26.80	2.60
2.00"	ASTM	PEX	1.653"	1.50"	7.20	0.13	4'5"	6.97	19.54	28.39	3.40
2.50"	63 mm	PEX	2.035"	1.50"	7.20	0.13	4'5"	8.04	21.40	30.67	3.80

## Rhinoflex Single Polyethylene • Chart 3

### Standard Products • Pre-Insulated HDPE Pipes

Nominal Pipe Size Inches	Carrier Pipe Size mm	Carrier Pipe Type	Carrier I.D.	Nominal Insulation Thickness	PE Jacket O.D.	Jacket Thickness	Bending Radius	Heat Loss (Btu/hr/ft)			Wt lb/ft
								dt 30	dt 100	dt 150	
1.50"	50 mm	PE	1.61"	1.25"	4.45	0.09	3'0"	3.63	12.10	18.14	1.45
2.00"	63 mm	PE	2.035"	1.28"	5.03	0.10	3'3"	4.14	13.81	20.17	1.75
2.50"	75 mm	PE	2.431"	1.34"	5.63	0.12	3'5"	4.50	15.00	22.50	2.28
3.00"	90 mm	PE	2.915"	1.44"	6.42	0.13	4'0"	4.88	16.27	24.40	3.06
4.00"	110 mm	PE	3.563"	1.05"	6.42	0.13	4'0"	7.27	24.22	36.33	3.82

Heat loss has been calculated with 3 different delta T's, 24" depth of bury, soil temperature of 50°F and soil conductivity of .12.

\* 230°F is intermittent, continuous operating temperature is 204°F maximum.

Rovanco's products are covered by various U.S. patents. Rovanco®, Insul-8®, Rhinoflex®, Rhinocoat® are federally registered trademarks.

Inch size pex pipes (3/4" - 2") meet or exceed the requirements of ASTM F876, F877, CSA B 137.5, PPI TR-3 and NSF 61. The size listed in the description is the nominal diameter according to ASTM F876. Inch size pipes are copper tube size, SDR 9. Metric pipes (50 mm - 140 mm) PEX and HDPE meet the requirements of DIN 16892 and 16893.

The size listed in the description is the nominal diameter in millimeters according to DIN 16893. Metric pipes are SDR 11. All Rhinoflex pipe will fit-up to all other types of ASTM and metric sized flexible pre-insulated piping systems. For more specific data regarding other pipe sizes, insulation thicknesses, pressure drop, heat loss, systems design, heat tracing or pricing, please contact your local Rovanco representative.

Rhinoflex is available exclusively from Rovanco Piping Systems, Inc.

### Rovanco Piping Systems, Inc.

20535 S.E. Frontage Road  
Joliet, Illinois 60431  
(815) 741-6700  
Fax (815) 741-4229  
Website: www.rovanco.com  
Email: marketing@rovanco.com

ISO 9001:2015  
CERTIFIED COMPANY



Rhinoflex manufactured by:

