

# Rovanco® Piping Systems

20535 S.E. Frontage Road  
Joliet, IL 60431  
(815) 741-6700

## Insul-8 Above Below Ground High Temp Conduit with Quick Fit Covers Installation Instructions

**INS-CHS**

Revised 03/13/24

### **GENERAL**

This instruction manual will give you all the information needed in terms of techniques, tools, and accessories required to install ROVANCO High Temp Conduit. If you follow the instructions carefully, the end result will be a high quality, pressure testable conduit piping system. Thank you for showing your confidence in ROVANCO by purchasing its products. We sincerely appreciate your business and we will provide you with quality products with a fair price and “great” service to deserve your future business. Please consult your local ROVANCO Manufacturer’s Representative for information about all of the products provided by ROVANCO.

### **INSPECTION**

Inspect all shipments on receipt. Examine all pipe and accessories as they are unloaded. Check to insure that every item on the packing list is received. Check the contents of the cartons to insure that the materials have arrived safely. Do not throw the cartons from the vehicle. Handle all materials carefully. Have the freight carrier make out a damage or short receipt if any discrepancies are found. Keep a signed copy of this receipt and notify ROVANCO immediately. All spool pieces shipped have individual part numbers labeled on each end. Refer to your packing list to be sure you have all spool pieces shown. With your paperwork, you will receive two copies of the installation drawings. These drawings will show the location of each piece of ROVANCO Conduit.

### **UNLOADING**

ROVANCO Insul-8 systems are manufactured to withstand normal field handling but, like any piping material, damage can occur from careless handling. The spool pieces should be unloaded from the truck using a cherry picker or other suitable equipment. Lift the pieces with nylon slings and spreader bars so as not to damage the epoxy coating. Do not use chains or chokers in direct contact with the epoxy coating. Do not drop spool pieces because this can damage the insulation, the epoxy coating, or the conduit.

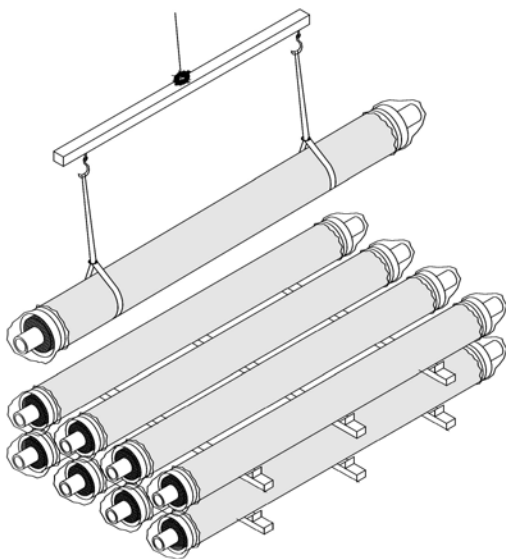

### **STORAGE**

Use dunnage material under the pipe and between successive layers to protect the casing from foreign objects. Do not stack more than four layers high to avoid excessive weight on the bottom layer. Prior to installation cover the pipe ends with a white tarp or white visqueen to keep out water, excessive dust and debris. If the pipe will be stockpiled in direct sunlight or at temperatures exceeding 90°F, cover the entire system with a white tarp or white visqueen. Do not use opaque, clear or any other color other than white. If these steps are not taken, warranty will be void. There should be a layer of wood dunnage between the pipe and visqueen. Cartons of material (i.e. glue, foam kits, fiberglass adhesives, etc.) should be stored in a dry area at 60° to 80°F. Liquid foam has a shelf life of 6 months after delivery. Freezing or high temperatures may affect the product’s ability to perform their functions. IF these steps are not taken, warranty will be void.

### **TESTING**

All carrier pipe must be hydro tested prior to insulating, pouring thrust blocks or backfilling the system. Failure to comply with testing procedures will void warranty.

## Table of Contents

Page

Section 1	Installation of Spool Pieces	3
Section 2	Cold Spring Requirements	4-5
Section 3	Field Alteration of Spool Pieces	5
Section 4	Welding of Carrier Pipe	6
Section 5	Insulation of Field Joints	7
Section 6	Welding & Testing of Connector Bands	7-8
Section 7	Test Can Application	9
Section 8	Wrap Around Shrink Instructions	10-12
Section 9	Quick Fit 90° and 45° Elbow Instructions	13-15
Section 10	Quick Fit Tees and Reducing Tees	16-18
Section 11	Field Applied End Seal	19
Section 12	Field Applied Gland Seal	19
Section 13	Field Applied Anchor	20
Section 14	Field Applied Split Anchor	21
Section 15	Conduit Coating & Testing	22-24
Section 16	Repairs To Containment	25
Section 17	Drying Inner Conduit Casing	26
Section 18	Manhole Or Building Entries	26
Section 19	Pouring Concrete Anchors	27
Section 20	Backfilling The System	27
Section 21	Cathodic Protection	28-29
Section 22	Operation and Maintenance Cathodic Protection	30-31
Section 23	Operation and Maintenance of Conduit System	32
Section 24	Parameters for Properly Installing & Operating Systems	33-34

## Testing

All carrier pipes must be hydro-tested and conduit must be air tested per the specifications prior to pouring thrust blocks or backfilling the system. Failure to comply with these procedures voids warranty.

ROVANCO's products and processes are covered under various US patents, including, but not limited to 4,084,842 - 4,484,386 - 4,221,405 - 3,793,411.

Insul-8 and ROVANCO are Federally Registered trademarks of ROVANCO Piping Systems, Inc.

**For Leak Detection Installation Instructions, contact Rovanco for INS-RAT**

## Section 1: Installation of Spool Pieces

Fig. 1.1

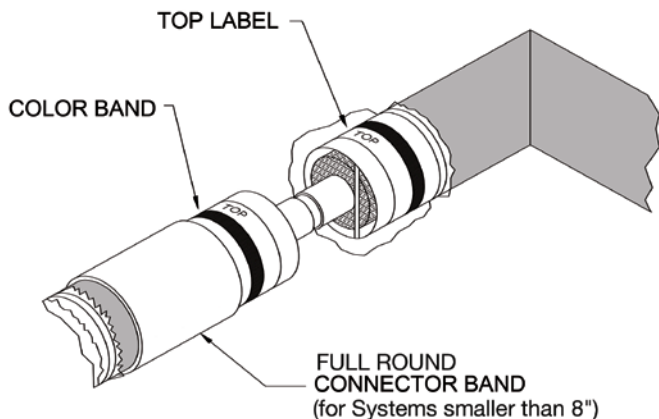

After the ditch has been opened, the spool pieces should be installed in accordance with the installation drawings bearing the latest revision number. Each spool piece has its own part number which will match the drawing showing its approximate length. There should be a full round connector band over one end of each spool (for systems less than 8"). If not, the connector band will come in two halves in a crate (for systems 8" and larger). It is important that one full round connector band be on the conduit at each joint joining section of pipe for systems smaller than 8" before welding the carrier pipe.

See Figure 1.1.

If the conduit is not going to be installed immediately, leave the plastic bag over the end of the pipe. Plastic garbage bags with the bottoms cut out or plastic sheeting can be taped over the connector band to help prevent water from entering the system should the trench flood. Test cans can be used at the open ends of the systems to prevent water from entering the system. It is very important that the insulation is kept dry during installation!

Fig. 1.2



ROVANCO suggests that you dig bell holes for field welding before lowering the pieces in the ditch. Lower the conduit into the trench, using a spreader bar and nylon slings. As pieces are lowered into the ditch, make sure that the trench bottom is free of sharp objects or rocks. If no bedding is specified, ROVANCO recommends 6" of sand or other clean granular material 1/4" or smaller. At no time is wood allowed to be buried as a pipe stand in the ditch. That is a potential failure point on all conduit systems. Bags of sand should be used.

Fig. 1.3

**ROVANCO**  
Piping systems, inc.

20535 S. E. Frontage Rd. • Joliet, Illinois 60431  
Phone: 815-741-6700 • Fax: 815-741-4229

-- THE LEADER IN PRE-INSULATED PIPING SYSTEMS --

SHOP ORDER NUMBER:		INSPECTED BY:
PART NUMBER:		
MATCH THIS END TO PART NUMBER:		

Check the drawings for possible cold spring locations. Notice that there are colored bands located on the end of some spool pieces. This band is to match an identical colored band of the adjacent piece at the field joint location. If you do not know what cold springing is, stop and read pages 4-5. See Figure 1.2

This is to ensure that expansion pipe supports are located in the proper areas. Also note that straight lengths coming off an expansion loop or elbow have a ROVANCO label marked TOP on the conduit end. This designates that these spool pieces have a top. This must be at the 12 o'clock position before the pipe is welded. This insures that the service pipe can move laterally within this special support. See Figure 1.2.

See Figures 1.3 for example labels.

## Section 2A: Pipe Cold Springing Requirements

Fig. 2a.1

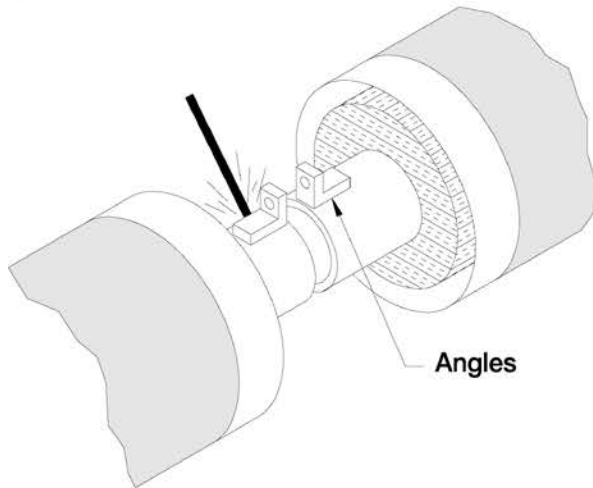

All systems do not require cold springing, refer to your ROVANCO site drawing to determine if the system you are installing requires cold springing. If so follow the instructions below, if not, go onto Section 3.

Refer to the ROVANCO installation drawings since an expansion elbow or a loop may require cold springing. The drawings will show you the amounts to cold spring at each leg. If the concrete anchor blocks can be poured before cold springing, use this method. When project scheduling requires that the cold-springing be completed prior to pouring concrete anchor blocks, the "Bridge Method" can be used. See Section 2B.

Be sure that all spool pieces except the cold spring locations are welded up first. Concrete anchor plates must be poured prior to this method of cold springing. When you skip the joint to be cold sprung, leave the cold spring amount gaped between the two pipes.

Fig. 2a.2

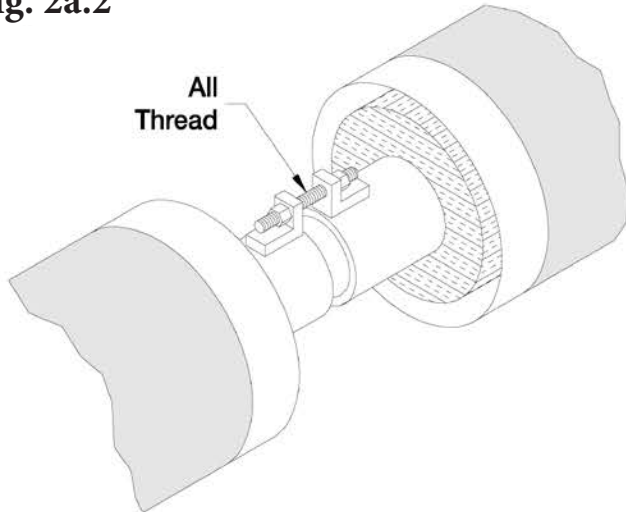

1. Weld angles with a bolt hole in it on each end of the carrier pipes. **See Figure 2.1**

**NOTE: Angles & rods NOT supplied by ROVANCO.**

2. Run a piece of all-thread rod through the holes and tighten until the two pipes meet. **See Figure 2.2**

Fig. 2a.3

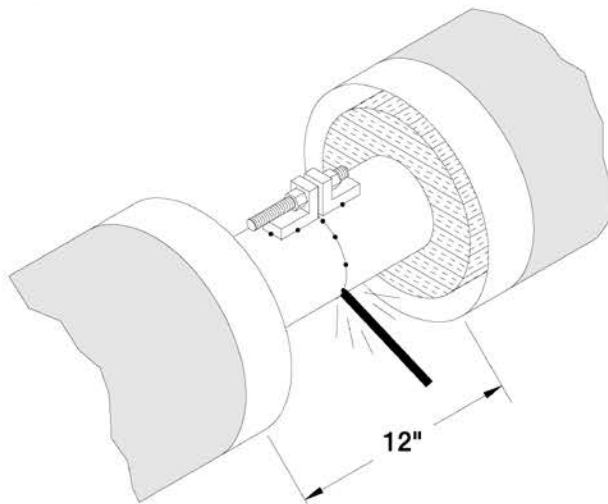

3. Tack weld the joint and remove the angles. Then complete the welding of this joint. **See Figure 2.3**

## Section 2B: Bridge Cold Springing

Fig. 2b.1

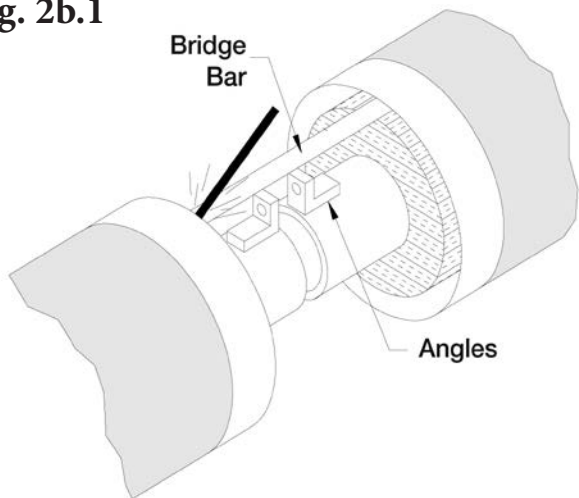

This method of cold springing allows cold springing to be done before anchors are poured in concrete.

1. Make sure that exactly 12" is maintained between the ends of the conduit.
2. Weld an angle iron "Bridge" between the conduit ends. The bridge should be welded on the inside of the conduit at 12 o'clock. This is to prevent interference while installing the connector band and yet maintain drainage of the conduit system. Make sure that a 12" gap is maintained between all conduit ends. Also make sure that the distance to be cold sprung is left between the pipe ends.

Fig. 2b.2

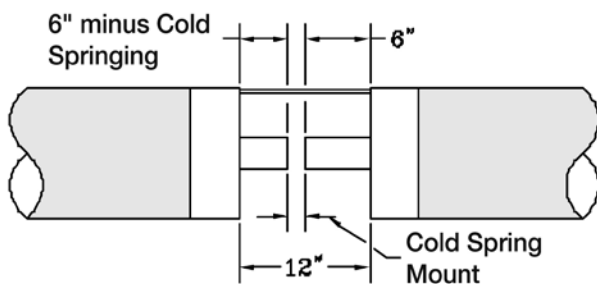

**See Figures 2b.1 and 2b.2.**

3. Install a "bridge" at every field joint in the run of pipe, including the joint to be cold sprung. I.E. anchor to end seal or gland seal, and anchor to anchor.
4. Weld angles with holes and run a piece of threaded rod through the holes and tighten. Weld the carrier pipe as with the standard cold springing instructions in Section 2a. Leave the bridges in place.

Fig. 2b.3

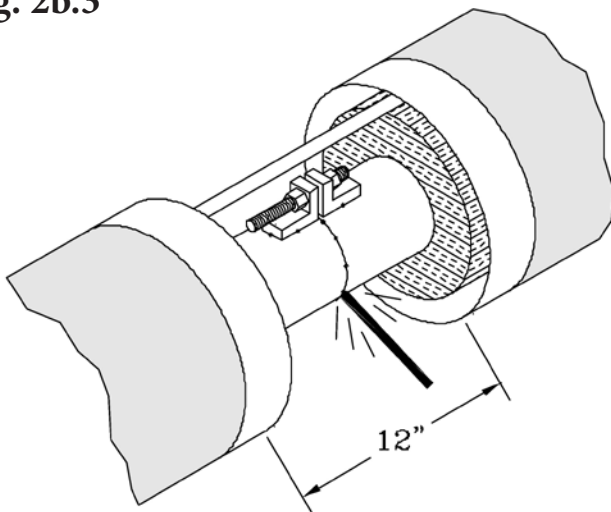

**See Figure 2b.3.**

5. For conduit sizes 12 $\frac{3}{4}$ " and larger, put two bridges, one at 3 o'clock, and one at 9 o'clock.

## Section 3: Field Alteration of Spool Pieces

Although the ROVANCO spool pieces have been fabricated in accordance with contractor field measurements, sometimes obstructions or errors can require field alteration. Prior to making any field alterations, contact ROVANCO's Customer Service Department in Joliet, Illinois (815) 741-6700, so that we can instruct you in this process and insure that the resulting layout will function properly. This prior notification will also maintain the ROVANCO warranty.

## Section 4: Welding of Carrier Pipe

Fig. 4.1

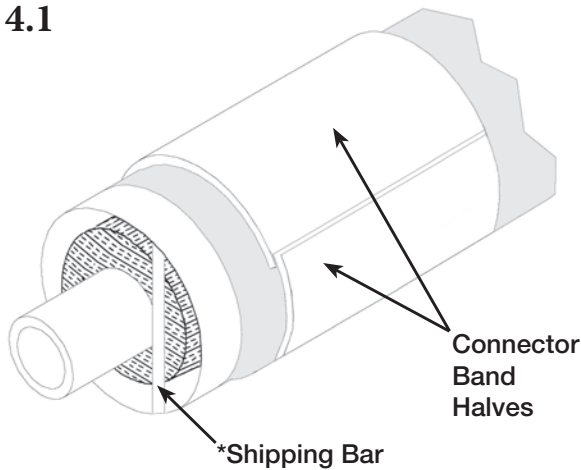

\* Note: Shipping bar needs to be removed prior to installation

**NOTE:** Prior to any carrier field welds, pipe ends must be prepped in the field by contractor.

**NOTE:** During the welding process do NOT use anti-splatter or any type of lubricant IF your system has leak detection. These materials can cause the leak detection to fail.

Prior to the welding of the carrier pipe, remove the shipping bar attached between the carrier pipe and outer conduit and clean up any remaining weld debris on the conduit. **The shipping bars have been put there to keep the pipe from sliding out of the conduit during transit, unloading, and lowering into the trench. These bars must be removed to allow the service pipe to expand during operation. See Figure 4.1**

After removing the shipping bar, you will find it easier to align the inner pipe. If cold springing is required, see Section 3. Align and weld the carrier pipe. If the carrier pipe is not welded immediately, slide the connector band over the joint, and cover the entire joint with a plastic bag or sheeting as described in Section 1. **See Figure 4.2**

If a hydrostatic test of the carrier pipe is not specified in the contract, ROVANCO recommends that a hydrostatic test be run on the internal pipe at 1½ times the job working pressure. This test should be done prior to insulating the field joints and welding the connector bands closed, to allow inspection and repair of welds if necessary.

If the installing contractor or owner does not want to conduct a hydrostatic pressure test then Rovanco will not be responsible for the cost to excavate and repair any carrier pipe leaks in the system regardless of who made the weld (Rovanco or the installing contractor).

Fig. 4.2

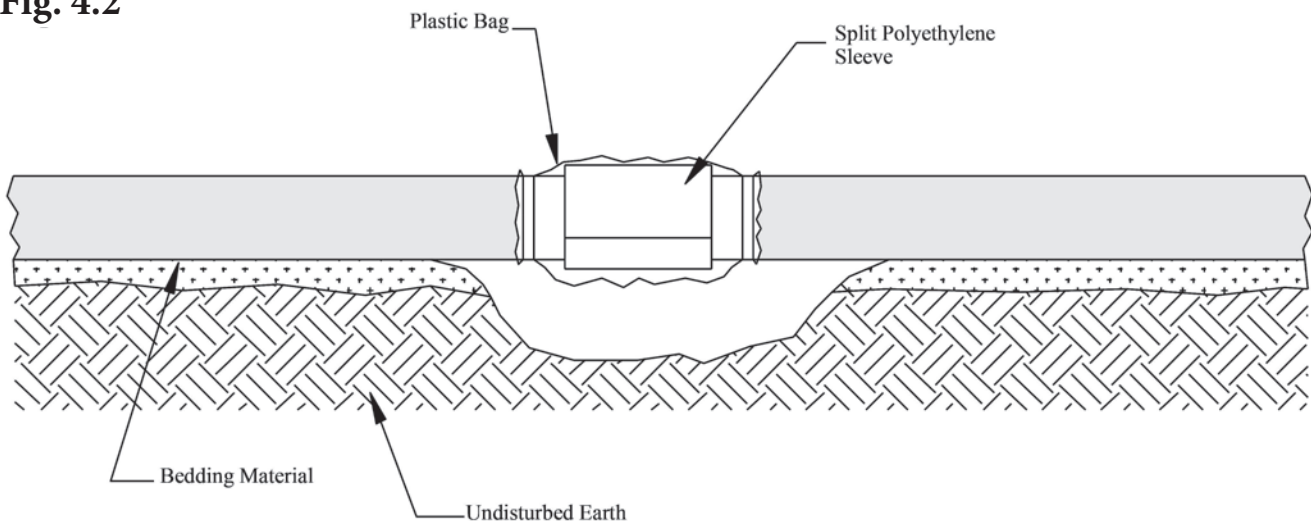

## Section 5: Insulating Field Joints

Fig. 5.1

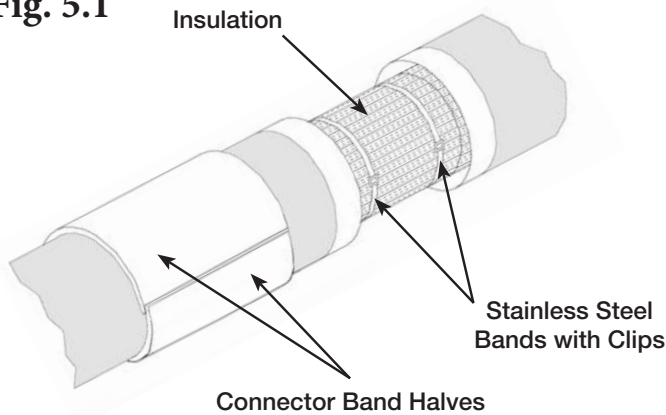

After the hydrostatic test has been completed, insulate the field joints. Sectional insulation has been provided in the cartons. Cut this insulation as required for each field joint and fasten with two stainless steel bands and clips, which have been provided by ROVANCO. See Figure 5.1.

## Section 6: Welding and Air Testing of Connector Bands

Fig. 6.1

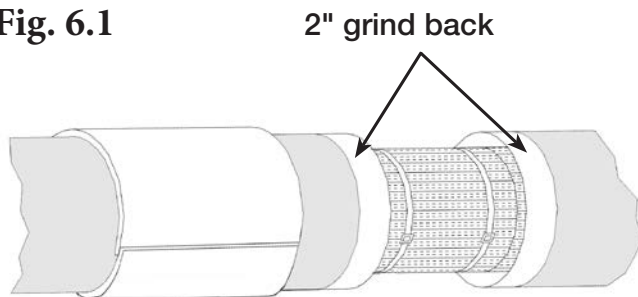

**NOTE:** It is the responsibility of the contractor to grind back both ends of the joint by 2" before installing the connector bands.

Ends should be ground to clean, bare metal that is free of any coatings to allow the welding of the connector bands. **It is suggested the grinding of the ends be done BEFORE lowering pipe into trench.** See Figure 6.1

Fig. 6.2

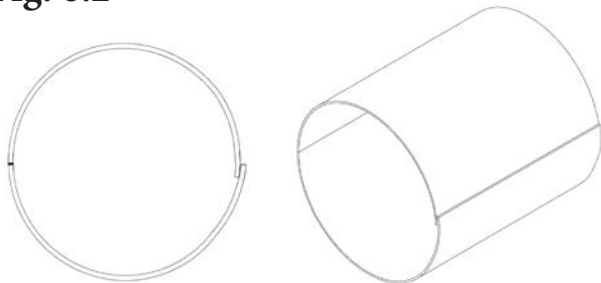

The length of each connector band is 15" to allow an overlap on your 12" joint area. The connector band is supplied in 2 equal length halves so there is no top or bottom half. Once the two bands are in place, centered over the joint, please note that one seam will be a butt fit and the other seam will be an overlap fit. This is the intended fit of the connector band. See Figure 6.2

Fig. 6.3

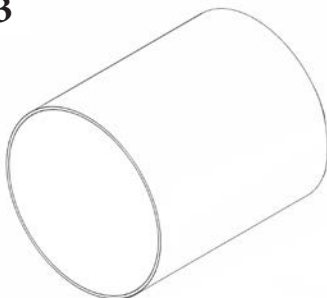

**NOTE:** If the system is 4" or 6" conduit, you will receive full round connector bands that will arrive banded to spools. See Figure 6.3

**Fig. 6.4**

Tack both edges of band to conduit

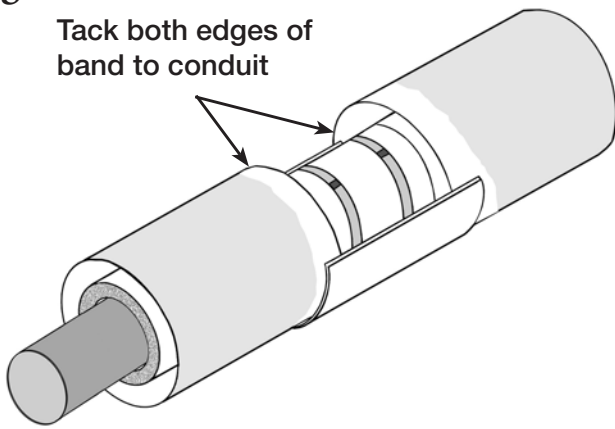

**NOTE: During the welding process do NOT use anti-splatter or any type of lubricant IF your system has leak detection. These materials can cause the leak detection to fail.**

To start (on 8" & larger systems), center one half over the bottom of the joint area. Tack that half in place with a couple quick tacks on each side of the connector band half along the same edge so it is semi-secured to the conduit.

**See Figure 6.4**

Place the other half of the connector band on top.

Remember, one seam will butt fit and the other will overlap. The top half should fit inside the bottom half on the side that overlaps. **See Figure 6.5**

Apply a ratchet tool or chain grips and tighten both halves of the connector band at once until they are pulled tight against the outer jacket. Tack top half in place with welds until the whole connector band is secure and will not move.

**See Figure 6.6**

Now fully weld the butt fit and overlap seams on the connector band as well as the full perimeter on both ends of the connector band where it meets the conduit. When done welding, joint should be air tight. **See Figure 6.7**

If it is a 4" or 6" system with full round connector band, slid band so centered over joint, apply ratchet tool or chain grips to secure and tack weld in several spots so band will not move. Then weld the full perimeter on both ends of the connector band. There will be no seam to weld.

**NOTE: Connector bands DO NOT come coated.**

They are sent bare unless otherwise stated in specifications. If system is coated, use Rovanco supplied material to coat connector bands after fully welding them. Otherwise, shrink wrap will serve as protection for the connector band.

**After all connector bands are fully welded, a 15 psi air test should be put on the inner casing prior to pouring thrust blocks or backfilling the system.**

Each connector band, gland seal, and testing apparatus should be checked for leaks with a soap and water test. If bubbles appear, a leak exists.

**NOTE: Depressurize prior to repairing leak. If you try to repair with the pressure still on the system, you are subject to blowing a larger hole at the leak area.** After leak is repaired, retest that area by re-soaping the repaired joint to ensure the leak has been fixed.

If possible, air test system as you install. ROVANCO can provide test cans in case you need to do an air test on only part of the system or on a watershed.

**Fig. 6.5**

Butt fit seam

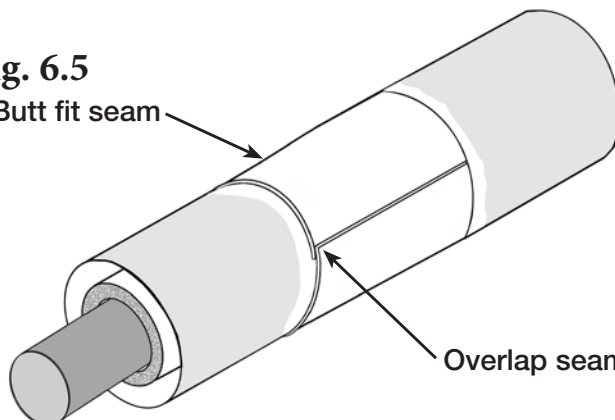

**Fig. 6.6**

Tack both edges along same seam on bottom connector band half

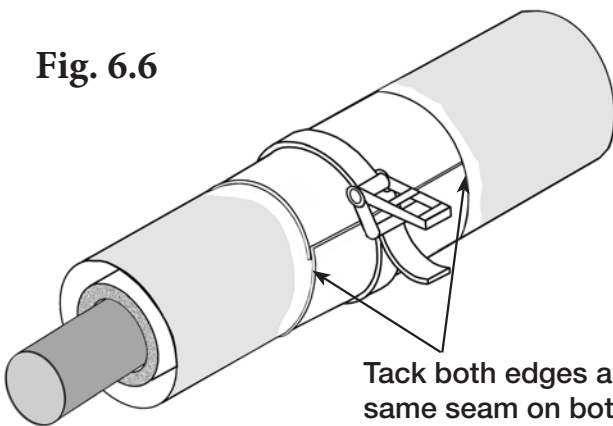

**Fig. 6.7**

Weld both butt & overlap seams on connector band

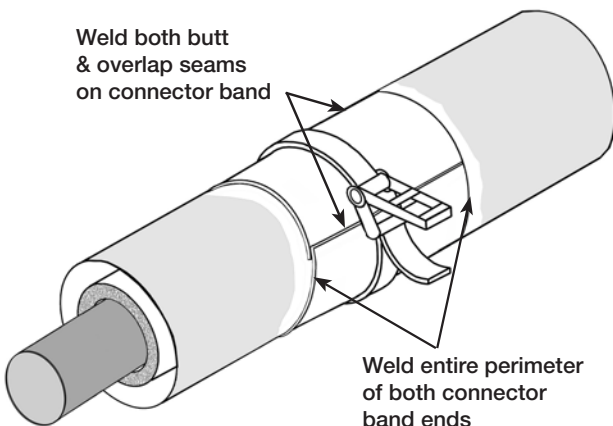

Weld entire perimeter of both connector band ends



## Section 7: Test Can Applications

Fig. 7.1

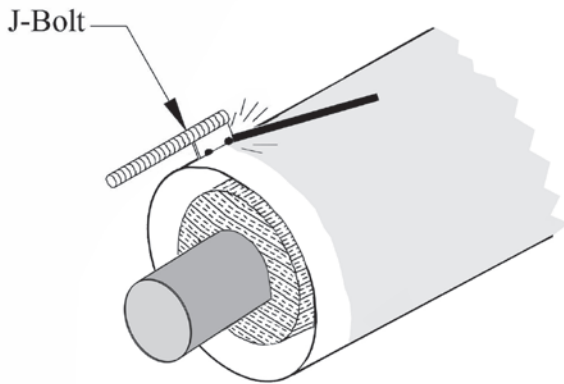

After Rovanco receives a release to manufacture, Rovanco's customer service will email test can purchase form to customer. Test cans need to be ordered before the first truck ships so they can ship with the job to save money on freight.

Remove any burrs on conduit ends that may have been caused by removing the shipping bar to ensure a proper seal. J bolts are then welded to the outer edge of the conduit. See Figure 7.1.

The test can butts up to an open end unit, is sealed with a gasket, and tightened down with bolts. Attach a safety chain around the test can and to other end of conduit. See Figures 7.2 and 7.3.

Fig. 7.2

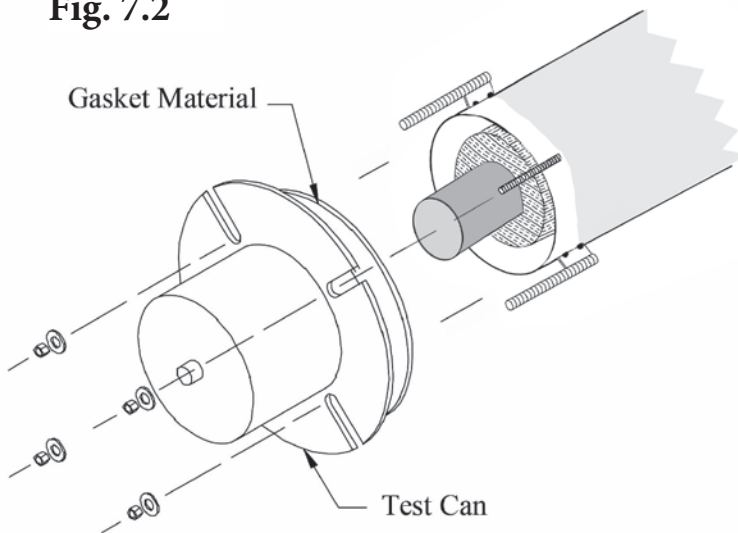

**CAUTION: No one in the area is to step in front of the test can during pressurization.**

After testing is complete, remove the test can and gasket and cut the J bolts off of conduit and grind or file down any burrs.

Fig. 7.3

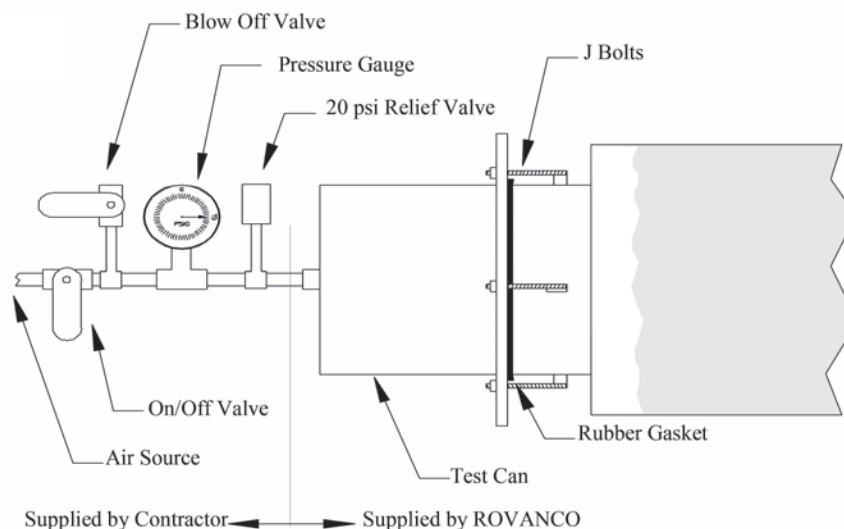

## Section 8: Applying Heat Activated Shrink Wrap

### (Only for Below Ground Installations)

#### Description:

Shrink wrap is shipped in predetermined bulk rolls 24" or 36" in width. It is to be applied over the insulated joint that has been enclosed in a polyethylene wrap or sleeve. The shrink wrap is necessary to protect the joint, and ensure a water tight system. A closure strip will be shrunk over the horizontal seam. The adhesive is built into the wrap, and only becomes apparent upon heat activation, protecting it from environmental factors. Closure strips are supplied as a separate component, and come in various lengths to match the width of respective wrap being installed. The table below serves as a guide as to what length you should cut the shrink wrap relative to the jacket size.

Jacket Pipe Size	Cut Length	Jacket Pipe Size	Cut Length
6"	2' - 1"	22"	6' - 3"
8"	2' - 7"	24"	6' - 10"
10"	3' - 2"	26"	7' - 4"
12"	3' - 8"	28"	7' - 10"
14"	4' - 2"	30"	8' - 4"
16"	4' - 8"	32"	9' - 0"
18"	5' - 3"	34"	9' - 5"
20"	5' - 9"	36"	10' - 0"

#### Suggested Equipment Necessary:

Propane tank, hose, torch with regulator (minimum torch size to be 150,000 BTU/hr.), surface prep tools to scuff the area, knife, roller, rags and cleanser, digital thermometer with probe, and necessary safety equipment (gloves, goggles, hard hat, steel toe boots, etc.).

#### General Product Guidelines:

- Overlap – each section should be cut to provide for a minimum of 4" overlap around the pipe.
- Closure Strip – Closure strip should be sized appropriately to match the width of shrink wrap being installed.
- It is important to make sure the shrink wrap and closure have no visible damage or contamination.
- **IMPORTANT** – Shrink wrap must be wrapped on the pipe around in the direction as it is spooled off the roll, failure to do so will inhibit the shrinking process from working properly.

#### Storage of Product:

It is important to understand that this shrink wrap product contains a built in adhesive that is activated by heat. Precautions should be taken to ensure proper storage where temperature is sufficiently below product adhesive activation temperature. Additional information about this product can be on its datasheet. Temperature considerations should take radiant heat from direct sunlight into account. In addition, extreme cold can cause damage to shrink wrap. Shrink wrap must be stored out of the sun or other harsh weather conditions, and at temperatures above -4 °F (20°C) and below 95 °F (65°C).

#### Surface Preparation:

1. Using some type of abrasive, such as a wire brush or sandpaper, scuff up the HDPE jacket area at least 2" beyond where the shrink wrap ends to ST3/SP3. This will assure ends of shrink wrap will have a strong seal to the HDPE jacket. Also remove any burs or loose pieces that may be present and that should effect shrink wrap material.
2. Wipe area with a clean cloth and rubbing alcohol or solvent cleaner to remove any debris or contaminants before applying shrink wrap.
3. Pipe needs to be totally dry before shrink wrap can be applied.

### Applying the Shrink Wrap:

4. Pre-heat the joint area to a minimum of 150 °F (65°C). Confirm temperature reached using digital thermometer with probe.
5. After centering the wrap over the joint, gently heat first 6 inches of wrap to activate the adhesive. A visual sign the adhesive has been activated is when it becomes shiny & looks to be wet. Position the starting edge you heated between 10 & 2 o'clock position on the pipe. This will assure the seam and the applying of the closure strip is in an area that will make it easier to accomplish. Press down firmly so starting edge is secured in place.
6. To assure wrap has been cut to the proper length, do a test fit by firmly pulling shrink wrap material around the joint so the closing end overlaps the starting end by at least 4". **Note** – if length measured properly, the closing edge of the wrap should overlap the starting edge and seam will end up somewhere near the top half of the pipe. Be sure you keep the edges of the wrap aligned as close as possible as you wrap the shrink around the pipe.
7. Once wrap length is confirmed as adequate, unwrap enough so you can heat the closing edge of the shrink wrap. Again pull wrap firmly and secure the heated closing edge in place by pressing down with a gloved hand.

### Applying the Closure Strip:

8. Pre-heat one end of the closure strip to activate adhesive. Position closure strip so it is centered over the seam and edge is aligned with shrink wrap edge. Press down firmly with a gloved hand to secure in place.
9. Continue heating closure strip as you work toward the other end, pressing down with a gloved hand as you go. Be sure to keep the closure strip in alignment so it remains centered on seam.
10. You can use a gloved hand or gentle pressure from a roller to work out any wrinkles or air pockets. This must be done after closure strip has been heated enough to activate the adhesive.

### Shrinking Down Wrap & Finishing Closure Strip:

11. Starting in the center, heat the shrink wrap with the torch using long continual passes up and down the shrink wrap working around the full diameter of the pipe. Start in the middle and work toward one end of the shrink wrap. Repeat again working from the middle to the other end, again working the full diameter of the shrink wrap and pipe. If closure strip requires additional heat for areas not totally shrunk down, you can do that as you heat the shrink wrap.  
**It is important to remain patient when shrinking down the wrap. DO NOT keep torch concentrated on a single area of the wrap. Keep the torch moving in a circular motion around the circumference of the shrink wrap until the wrap is fully shrunk down everywhere.**
12. As the wrap shrinks down to the pipe, pressing down with a gloved hand or gently using a roller over entire surface will help work out air bubbles and wrinkles if they appear. This must be done while the shrink wrap is still hot and/or after it has been heated enough to activate the adhesive, but do not attempt when actively using the torch of you could get burned. It may be necessary to re-heat areas and pressing down again to fully complete this step.
13. The process will be complete when the wrap & closure strip are totally shrunk down on the pipe and adhesive is seen coming out the edges of shrink wrap, all the way around the full circumference of the pipe and on both ends.

### Completion and Verification Measures:

14. Ensure the area is free from visual flaws. Be sure the shrink wrap is in full contact in all areas & totally shrunk down. Adhesive has flowed out of both edges of the shrink wrap all the way around the diameter of the pipe. There are no cracks or holes in the shrink wrap from over heating, sharp objects or mishandling.
15. Inspect closure strip to be sure it is fully shrunk down and has totally sealed the shrink wrap seam.
16. Allow shrink wrap to cool a minimum of 2 hours prior to backfilling and burying pipe.
17. Certain backfill material may damage shrink wrap and reduce corrosion protection provided by the shrink wrap. Make sure backfill material is free from sharp stones or other large particles. If this cannot be achieved, further protection of the shrink wrap may be necessary.

**NOTE:** The application of the shrink wrap & closure strip instructions above are repeated on page 16 in a Step-By-Step process and supported with pictures that might lend some additional visual guidance.

## Step-By-Step

### Step 1. Preparation

- Ensure joint area is free of debris and contaminants to ensure proper bonding. See “Suggested Surface Preparation” on Page 14 for optimal results.
- Cut shrink wrap to desired length to properly overlap a minimum of 4" (10 cm). The table on page 14 shows the wrap length relative to the jacket size.
- Cut closure strip should properly span entire seam. Check this before apply closure strip and trim as necessary if it is not.

### Step 2. Tack Shrink Wrap To Surface

- Pre-heat the joint area to a minimum of 150° F (65° C)
- Gently heat first 6 inches (15 cm) of wrap and for the full width to activate adhesive and tack it to the pipe at the 2 o'clock position
- Center wrap over the joint and wrap from backside under the joint then up and back over the front so closing end finishes at approximately 12 o'clock.
- Firmly wrap the pipe joint to ensure the proper overlap. Confirm the ending seam is at approximately the 12 o'clock position, or close to it.
- Use same gentle heating technique the full width of the wrap's closing end until adhesive is activated. Tack overlap into place. You may have to heat more of the shrink wrap in colder conditions to hold it in place before applying closure strip and fully shrinking it down.

### Step 3. Apply The Closure Strip

- Pre-heat closure strip on one end to activate adhesive. Center closure strip on the seam/overlap and align closure strip end with end of shrink wrap. Press firmly to ensure closure strip holds.
- Heat closure strip as you go to fully activate adhesive, patting it down periodically with a gloved hand. Be sure closure strip remains centered on the seam.
- Continue process moving from one end to the other until closure strip is fully bonded. Closure strip should end aligned with the other end of the shrink wrap.
- While closure strip is still hot, press down or use a roller to remove air bubbles or wrinkles.

### Step 4. Shrink The Wrap

- As you shrink down the wrap, you can additional heat to the closure strip if there are areas that have not fully shrunk down.
- Starting from the center and working toward one end, begin heating the shrink wrap in the center, using long continual passes up and down the wrap applying heat around the full diameter of the pipe. The shrink wrap should settle into place snug to the pipe with no bubbles or wrinkles. Smooth out with a gloved hand or apply gentle pressure with a roller to remove any bubbles or wrinkles while wrap is still hot but you are not actively heating it with the torch so you don't get burned.
- Repeat previous process beginning back in the center and working toward other end of shrink wrap not yet shrunk down.

**It is important to remain patient when shrinking down the wrap. DO NOT keep torch concentrated on a single area of the wrap. Keep the torch moving back and forth over the full area of the shrink wrap until the wrap is fully shrunk down everywhere.**

- Process is complete when adhesive is seen coming out the edges of the wrap, all the way around the full circumference of the pipe, and on both ends. Failure to continue heating until adhesive can be visually seen flowing out edges as described will void warranty.
- To work out any pockets of glue build up, continue heating from side to side around entire area. See "Completion and Verification Measures" on page 15 for some practices that will confirm the process has been finalized.

### Step 1



### Step 2



### Step 3



### Step 4



## Section 9A: Quick Fit 90° & 45° Elbow Instructions – **Smaller Than 8" System**

**Note:** If the system is to be installed **ABOVE GROUND**, the conduit jacket and Quick Fit fittings will be coated with Red Mill primer or fusion bonded epoxy, in either case the weld areas, fittings and any cuts, scrapes or gauges in the coating should be touched up.

If the system is to be installed **BELOW GROUND**, the conduit jacket will be coated with 20 mils of fusion bonded epoxy. Fittings are to be field coated with epoxy if specified, otherwise polyethylene shrink will serve as coating.

Fig. 9A.1

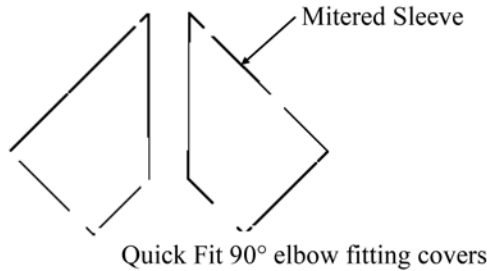

**NOTE:** *Prior to any carrier field welds, pipe ends must be prepped in the field by contractor.*

**NOTE:** *During the welding process do NOT use anti-splatter or any type of lubricant IF your system has leak detection. These materials can cause the leak detection to fail.*

You will receive a Rovanco "Quick Fit" fitting cover kit consisting of two mitered sleeves.  
See Figure 9A.1

Fig. 9A.2

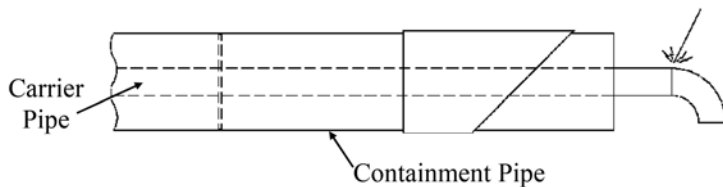

Prior to joining the carrier pipes to the fitting, slide the mitered sleeves onto the conduit pipe outer jacket. Weld one side of the carrier pipe fitting into place. See Figure 9A.2

Fig. 9A.3

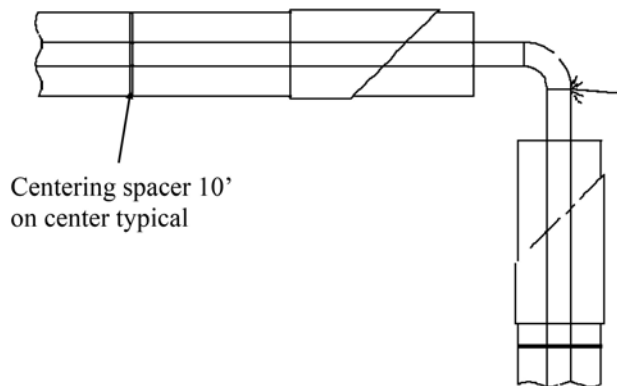

Slide the second mitered sleeve over the conduit pipe. See Figure 9A.3

Fit up the next length of pipe and weld the other side of the fitting.

Test the carrier pipe per specifications.

Slide the mitered sleeves into position. Weld all circumferential seams. See Figure 9A.4

Unless otherwise specified, Rovanco recommends a 15 psi air test on the conduit jacket. Clean welds and apply a soap and water test to the welds. If bubbles appear, a leak exists.

Fig. 9A.4

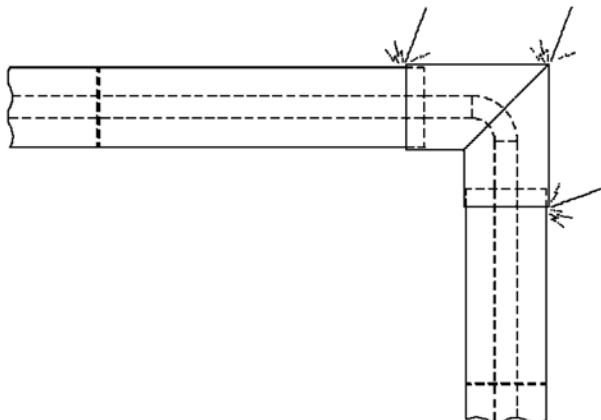

**NOTE:** *Depressurize prior to repairing leak. If you try to repair with the pressure still on the system, you are subject to blowing a larger hole at the leak area.* After leak is repaired, retest that area by re-soaping the repaired joint to ensure the leak has been fixed. If possible, air test system as you install.

## Section 9B: Quick Fit 90° & 45° Elbow Instructions – 8" and Larger System

**Note:** If the system is to be installed **ABOVE GROUND**, the conduit jacket and Quick Fit fittings will be coated with Red Mill primer or fusion bonded epoxy, in either case the weld areas, fittings and any cuts, scrapes or gauges in the coating should be touched up.

If the system is to be installed **BELOW GROUND**, the conduit jacket will be coated with 20 mils of fusion bonded epoxy. Fittings are to be field coated with epoxy if specified, otherwise polyethylene shrink will serve as coating.

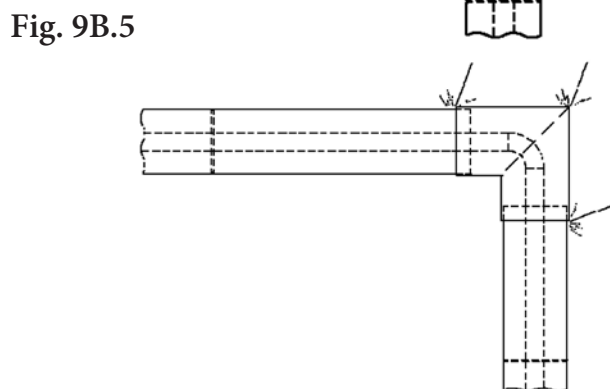
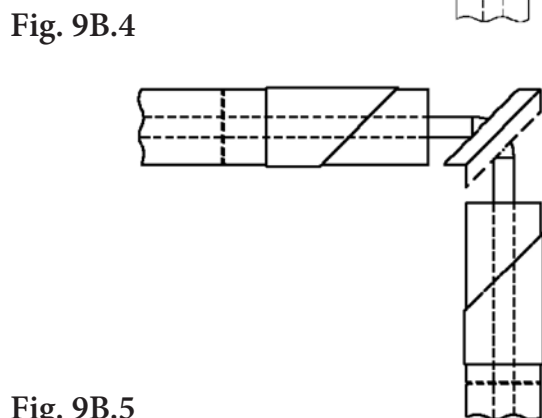
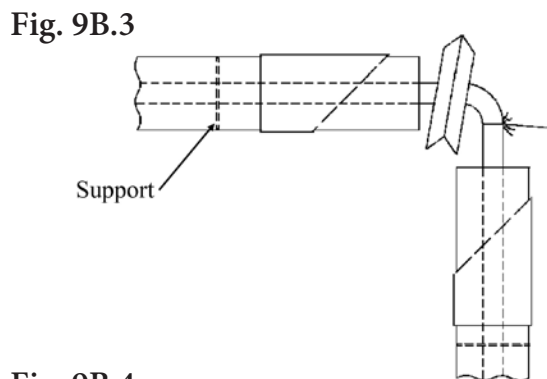
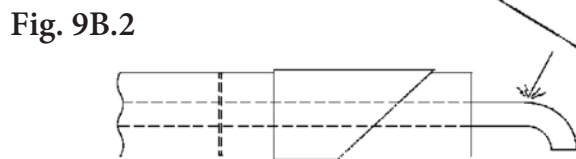
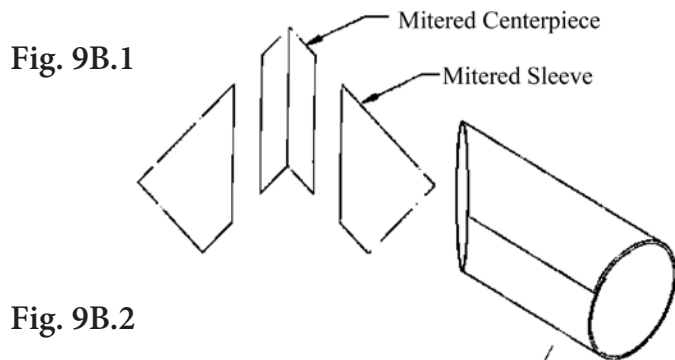

**NOTE:** Prior to any carrier field welds, pipe ends must be prepped in the field by contractor.

**NOTE:** During the welding process do NOT use anti-splatter or any type of lubricant IF your system has leak detection. These materials can cause the leak detection to fail.

You will receive a Rovanco "Quick Fit" fitting cover kit consisting of two mitered sleeves and a mitered center piece. See Figure 9B.1

Prior to joining the first carrier pipe to the fitting, slide one of the mitered sleeves onto the conduit jacket. Weld one side of the carrier pipe fitting into place. See Figure 9B.2

Fit up the second carrier pipe and weld the other side of the fitting. Be sure that the mitered sleeve has been slid over the conduit jacket prior to welding the second pipe to the fitting. See Figure 9B.3

Test the carrier pipe per specifications.

Slide the mitered sleeves into position. The mitered sleeve for 10" and larger sizes have an overlap seam at the bottom. See Figure 9B.4 and 9B.5

Tack the tops of the mitered sleeves to the conduit jacket and the mitered center piece, then using a ratchet strap pull the mitered sleeve down tight to the conduit jacket and weld all seams. See Figure 9B.6

Unless otherwise specified, Rovanco recommends a 15 psi air test on the conduit jacket. Clean welds and apply a soap and water test to the welds. If bubbles appear, a leak exists.

**NOTE:** Depressurize prior to repairing leak. If you try to repair with the pressure still on the system, you are subject to blowing a larger hole at the leak area. After leak is repaired, retest that area by re-soaping the repaired joint to ensure the leak has been fixed. If possible, air test system as you install.

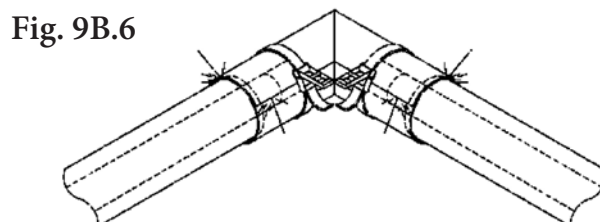

## Section 9C: Shrink Wrapping Elbows

Fig. 9C.1

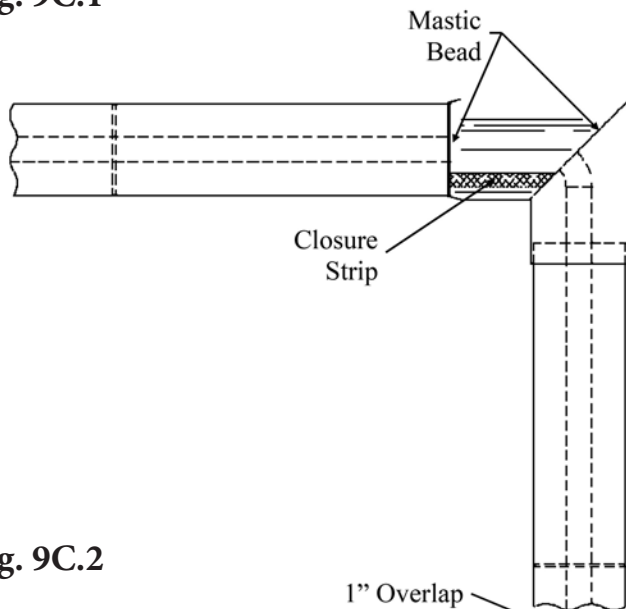

Fig. 9C.2

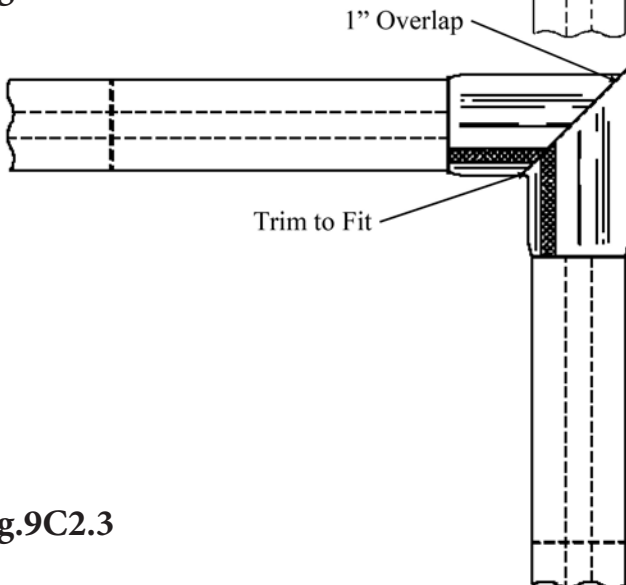
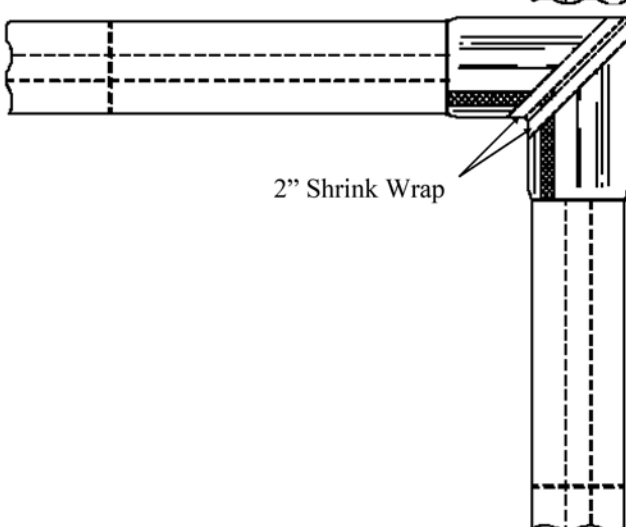

Fig. 9C.2.3



(Only required on Below Ground installations)

### ELBOWS

Tools needed:

(Not Supplied by Rovanco)

Propane Broad Tip Torch

Gloves

Utility Knife

Wall Paper Seam Roller

(Material Supplied by Rovanco)

Polyethylene Shrink Wrap in bulk

4" Wide Closure Strip

2" Wide Shrink Wrap cut from bulk

Shrink Wrap Templates

To aid the installer in cutting the bulk shrink wrap material to the proper size, Rovanco will provide a template for each size fitting required for each order.

Apply shrink wrap material to half of the fitting. Next, center the closure strip on the horizontal seam where the shrink overlaps. Heat the closure strip and roll it onto the shrink wrap using the wall paper roller. **See figure 9C.1**

Heat the shrink material by moving the torch quickly and thoroughly around the material until it has shrunk down and a bead of mastic can be seen around the edges.

**See Figure 9C.1**

Repeat the procedure for the other half, except overlap the shrink on the miter 1". **See figure 9C.2**

After shrink wrapping is complete, apply two wraps of 2" wide shrink wrap to the mitered seam. **See figure 9C.3**

## Section 10A: Split Half Shell Tees & Reducing Tees

**Note:** If the system is to be installed **ABOVE GROUND**, the conduit jacket and Quick Fit fittings will be coated with Red Mill primer or fusion bonded epoxy, in either case the weld areas, fittings and any cuts, scrapes or gauges in the coating should be touched up.

If the system is to be installed **BELOW GROUND**, the conduit jacket will be coated with 20 mils of fusion bonded epoxy. Fittings are to be field coated with epoxy if specified, otherwise polyethylene shrink will serve as coating.

**Note: Rovanco supplies tees in two different forms: Split Half Shell and 3-Piece Mitered.**

See Section 10B for 3-Piece Mitered Tees.

Fig. 10A.1

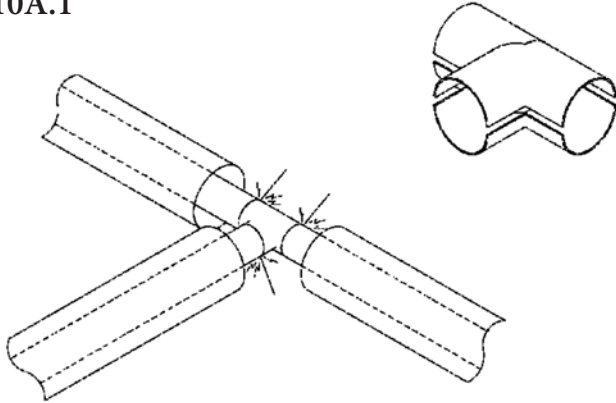

**NOTE: Prior to any carrier field welds, pipe ends must be prepped in the field by contractor.**

**NOTE: During the welding process do NOT use anti-splatter or any type of lubricant IF your system has leak detection. These materials can cause the leak detection to fail.**

**Note:** If you are installing a below ground system, prior to joining the carrier pipes to the fitting, cut a hole in a length of shrink wrap and slide the shrink over the branch conduit pipe. See the instructions in **Section 4**, on **page 7** and the table on **page 9** for length to cut shrink wrap.

Fig. 10A.2

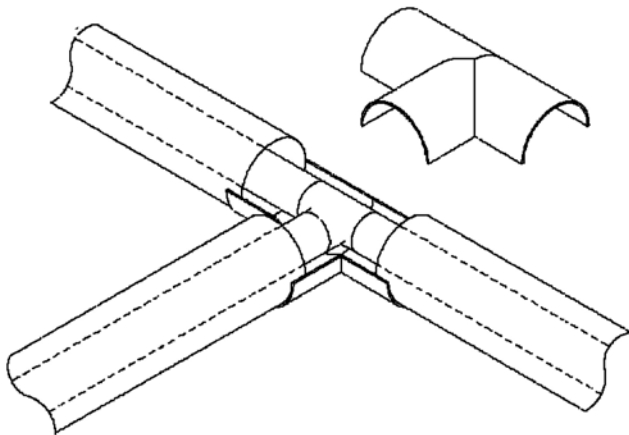

You will receive a Rovanco "Quick Fit" fitting cover kit consisting of two half shells. Weld the carrier pipe fitting into place. **See Figure 10A.1**

Test the carrier pipe per specifications.

Test fit the cover prior to welding either piece in place. Fit up the bottom half of the fitting cover in place and tack weld it. **See Figure 10A.2**

Fig. 10A.3

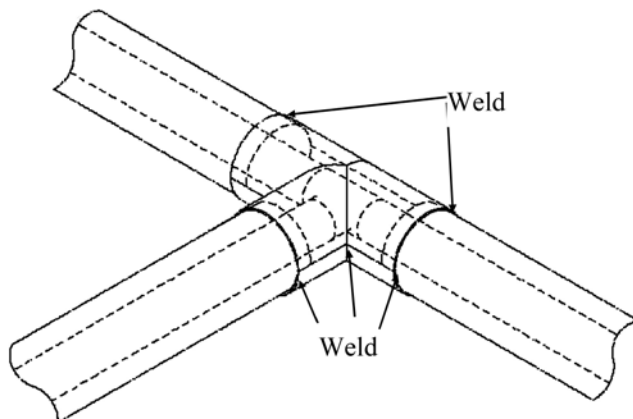

Next fit the top half in place and tack weld it. Continuously weld all circumferential seams and the longitudinal seams to completely seal the fitting cover. **See figure 10A.3**

Unless otherwise specified, Rovanco recommends a 15 psi air test on the conduit jacket. Apply a soap and water test to the welds. If bubbles appear, a leak exists.

**NOTE: Depressurize prior to repairing leak. If you try to repair with the pressure still on the system, you are subject to blowing a larger hole at the leak area. After leak is repaired, retest that area by re-soaping the repaired joint to ensure the leak has been fixed. If possible, air test system as you install.**



## Section 10B: 3-Piece Mitered Tees & Reducing Tees

**Note:** If the system is to be installed **ABOVE GROUND**, the conduit jacket and Quick Fit fittings will be coated with Red Mill primer or fusion bonded epoxy, in either case the weld areas, fittings and any cuts, scrapes or gauges in the coating should be touched up.

If the system is to be installed **BELOW GROUND**, the conduit jacket will be coated with 20 mils of fusion bonded epoxy. Fittings are to be field coated with epoxy if specified, otherwise polyethylene shrink will serve as coating.

**Note:** Rovanco supplies tees in two different forms: **Split Half Shell** and **3-Piece Mitered**.

See **Section 10A** for Split Half Shell Tees.

Fig. 10B.1

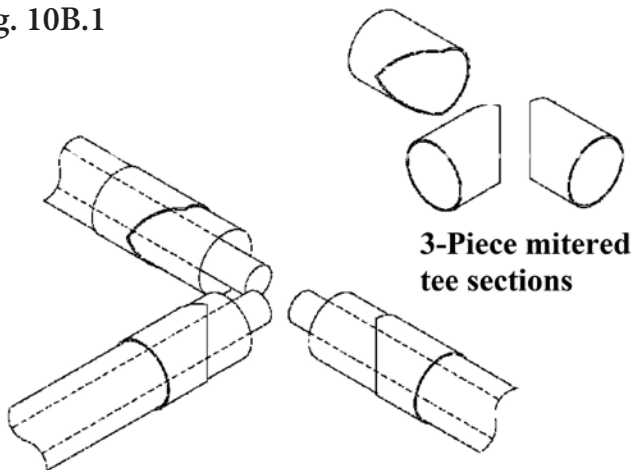

**NOTE:** Prior to any carrier field welds, pipe ends must be prepped in the field by contractor.

**NOTE:** During the welding process do **NOT** use anti-splatter or any type of lubricant **IF** your system has leak detection. These materials can cause the leak detection to fail.

**Note:** If you are installing a below ground system, prior to joining the carrier pipes to the fitting, cut a hole in a length of shrink wrap and slide the shrink over the branch conduit pipe. See the instructions in **Section 4**, on **page 7** and the table on **page 9** for length to cut shrink wrap.

Fig. 10B.2

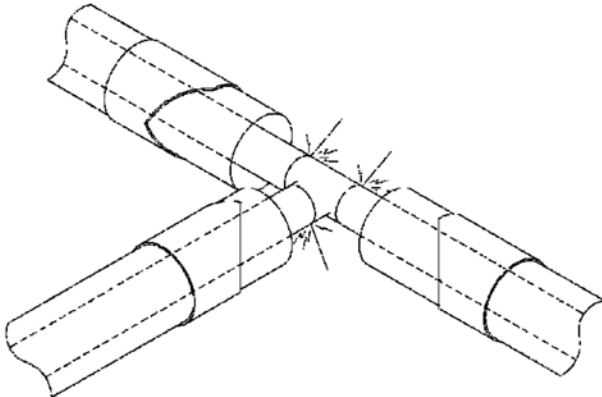

You will receive a Rovanco "Quick Fit" fitting cover kit consisting of three mitered sections. Prior to welding the carrier pipe fitting into place, you will need to slip the mitered sections over the conduit jacket. **See Figure 10B.1**

Weld the carrier pipe fitting. **See Figure 10B.2**

Test the carrier pipe per specifications.

Fig. 10B.3

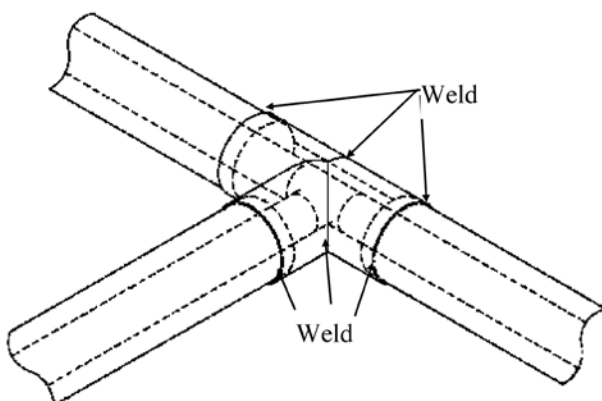

Test fit the mitered section prior to welding them in place. Fit up the three sections to each other and tack weld them in place. Continuously weld all circumferential seams and the mitered seams to completely seal the fitting cover. **See figure 10B.3**

Unless otherwise specified, Rovanco recommends a 15 psi air test on the conduit jacket. Apply a soap and water test to the welds. If bubbles appear, a leak exists.

**NOTE:** Depressurize prior to repairing leak. If you try to repair with the pressure still on the system, you are subject to blowing a larger hole at the leak area. After leak is repaired, retest that area by re-soaping the repaired joint to ensure the leak has been fixed. If possible, air test system as you install.

## Section 10C: Shrink Wrapping Tees & Reducing Tees

Fig. 10C.1

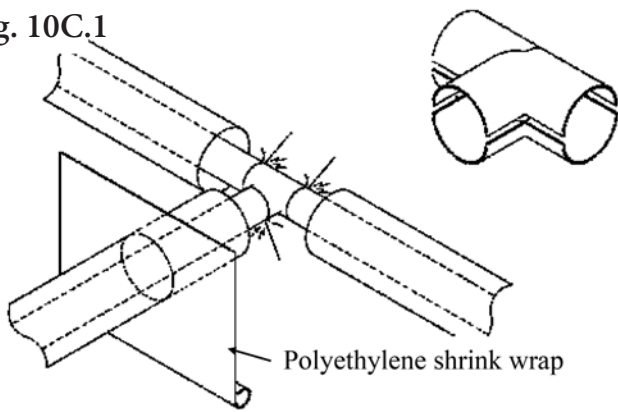

(Only required on Below Ground installations)

As noted on the previous page, the shrink wrap section should be on the branch. **See Figure 10C.1**

The tee cover should be installed and tested as per Section 3, and you are now ready to shrink the tee cover.

Pull the shrink back over the fitting cover.

**See figure 10C.2**

Fig. 10C.2

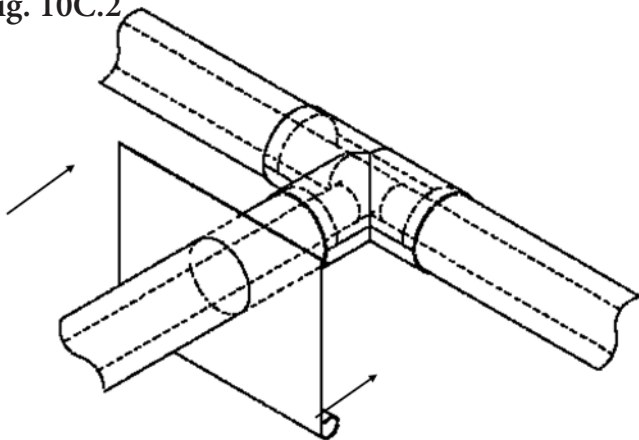

Wrap the shrink around the fitting and apply a closure strip. Evenly heat the shrink to a snug fit.

**See figure 10C.3**

Cut another section of shrink to fit around the branch line. Keep the shrink as close to the main as possible. Once again apply heat until the shrink is snug in place.

**See figure 10C.4**

Fig. 10C.3

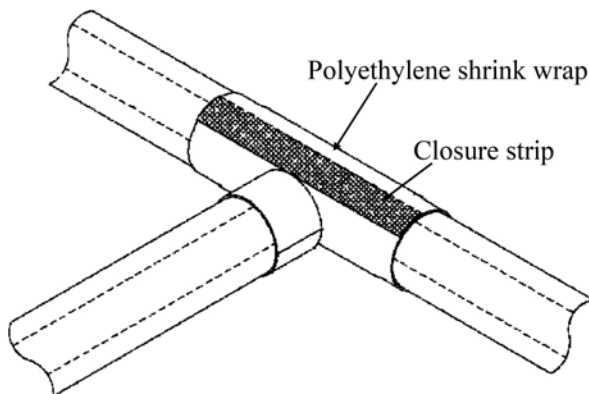

After shrink wrapping is complete, apply two wraps of 2" wide shrink wrap tape to the seam to seal the seam between the two pieces of shrink. **See figure 10C.5**

Fig. 10C.4

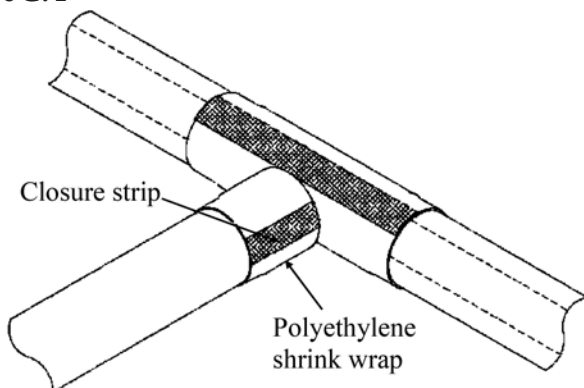
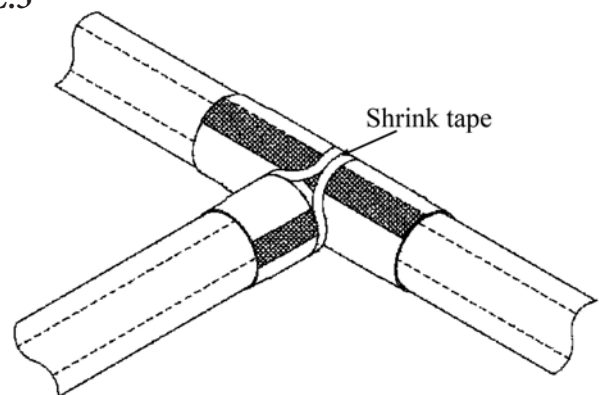
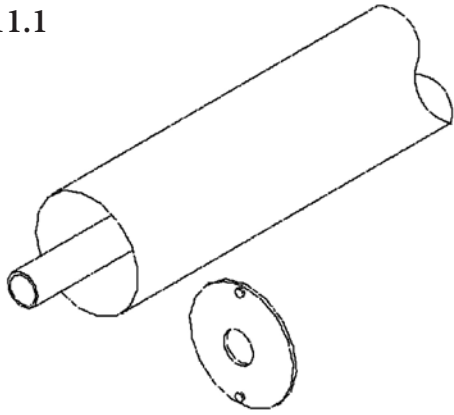

Fig. 10C.5



## Section 11: Field Applied End Seal

Fig. 11.1



**NOTE: During the welding process do NOT use anti-splatter or any type of lubricant IF your system has leak detection. These materials can cause the leak detection to fail.**

If the job requires a field applied end seal, you will receive a precut end seal plate with your shipment.

**See Figure 11.1**

Fig. 11.2

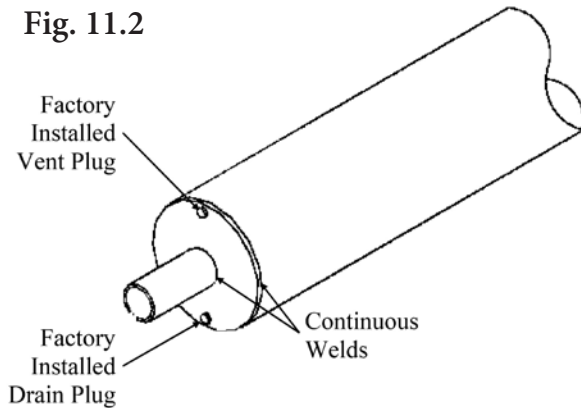

Take the plate and slide it over the open end of pipe where it is required. Make sure to align the vent and drain plugs at the 6 o'clock and 12 o'clock positions. Continuously weld the plate to the carrier pipe and outer conduit jacket. **See Figure 11.2**

After air testing the conduit jacket, coat the plate and welds with epoxy.

## Section 12: Field Applied Gland Seal

Fig. 12.1

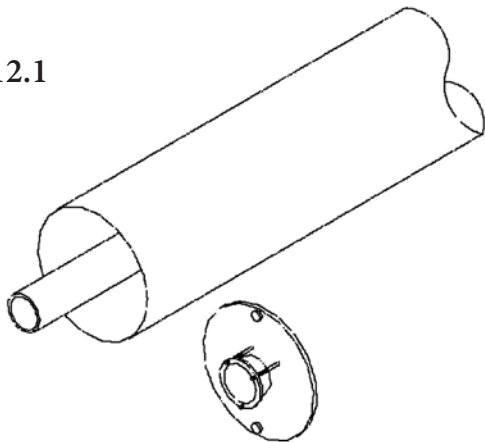

**NOTE: During the welding process do NOT use anti-splatter or any type of lubricant IF your system has leak detection. These materials can cause the leak detection to fail.**

If the job requires a field applied gland seal, you will receive a pre-cut gland seal plate with a gasket and follower plate attached. **See Figure 12.1**

Fig. 12.2

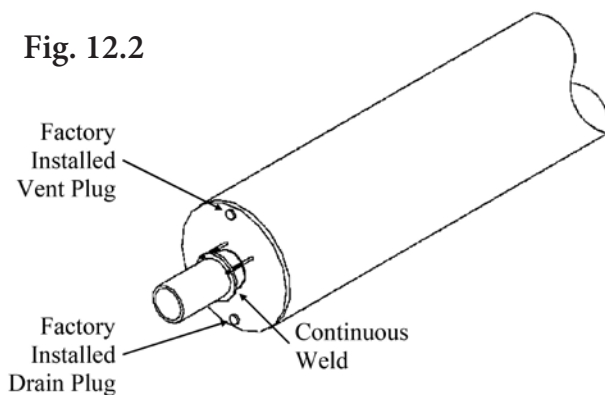

Remove the gasket and follower plate and slide the gland seal plate over the open end of pipe where it is required. Make sure to align the vent and drain plugs at the 6 o'clock and 12 o'clock positions. Continuously weld the plate to the jacket. Slide the gasket and follower plate into place and tighten it up so that the plate is centered and secure. **See figure 12.2**

After air testing the outer jacket, coat the plate and welds with epoxy.

## Section 13: Field Applied Anchor

Fig. 13.1

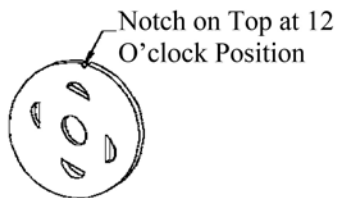

**NOTE: During the welding process do NOT use anti-splatter or any type of lubricant IF your system has leak detection. These materials can cause the leak detection to fail.**

Fig. 13.2

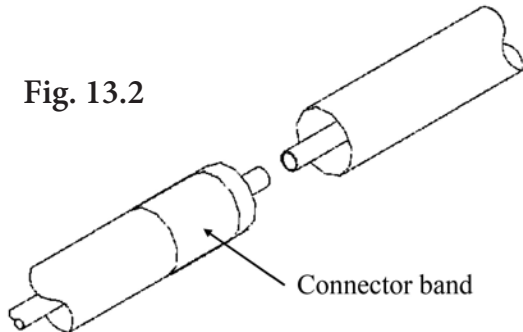

If the job requires a field applied anchor, you will receive a pre-cut anchor plate with your shipment. The anchor has pre-cut vent holes and a notch cut into the plate. The notch has to be installed at the 12 o'clock position.

**See figure 13.1**

Fig. 13.3

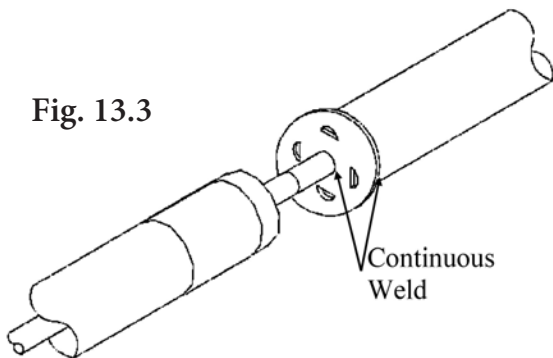

There are two methods of installing field applied anchors, either at a field joint or by cutting into a length of pipe. To apply an anchor at a field joint, continue with the instructions on this page. For instruction on field cutting pipe and split anchor application, refer to **Section 14 on page 21.**

To apply the anchor plate at a field joint, first make sure that a connector band is slid onto one side of the pipe where the anchor is to be applied (opposite of the side that the anchor plate will be welded). **See figure 13.2**

Fig. 13.4

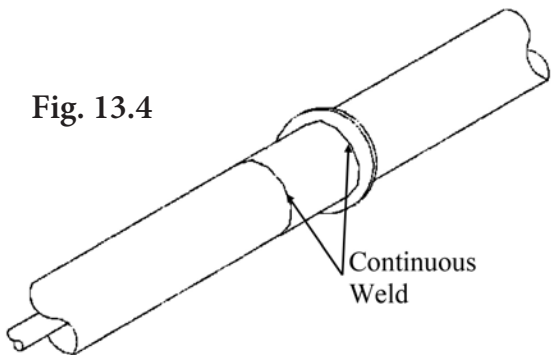

Slide the anchor plate up against the open end of the conduit pipe jacket. Continuously weld the anchor plate to the conduit jacket and on the opposite side of the anchor plate, continuously weld the anchor plate to the carrier pipe. **See figure 13.3**

Slide the connector band up to the anchor plate to verify the outer coating has been ground back far enough to weld. Grind outer coating off the weld area, if needed. Slide the connector band back against the anchor plate. Continuously weld the connector band to the anchor plate and the conduit jacket. **See figure 13.4**

Fig. 13.5

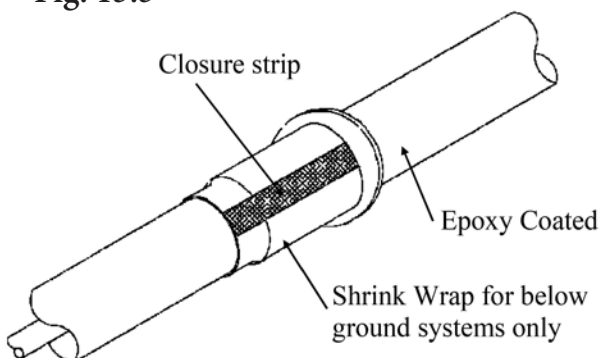

After air testing the outer jacket, clean the exposed metal surface thoroughly. Next, coat the anchor plate with epoxy or Red Mill primer to the connector band, and over any exposed steel on the opposite side. **See figure 13.5**

## Section 14: Field Applied Split Anchor

Fig. 14.1

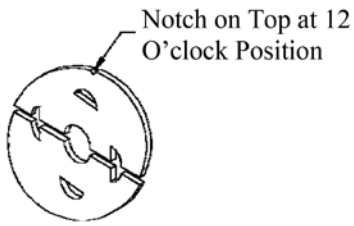

Fig. 14.2

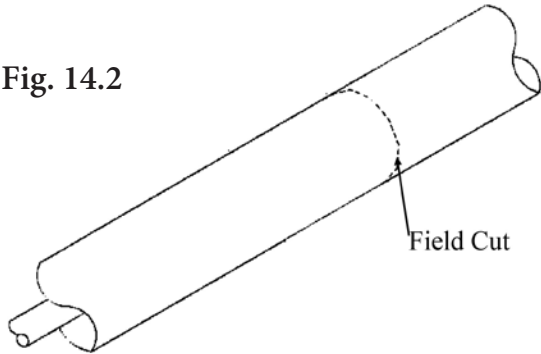

Fig. 14.3

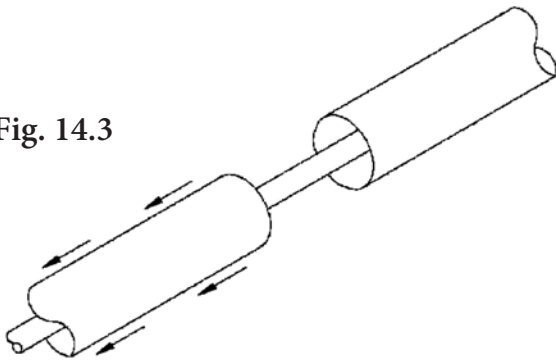

Fig. 14.4

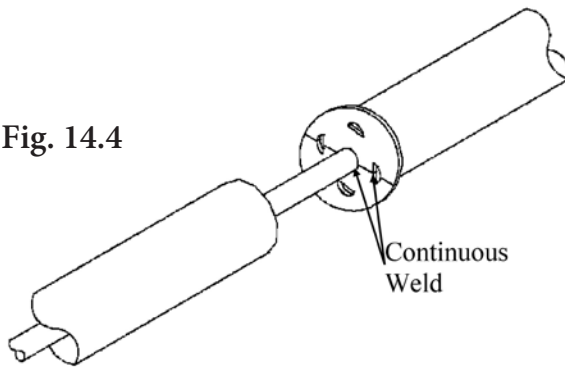
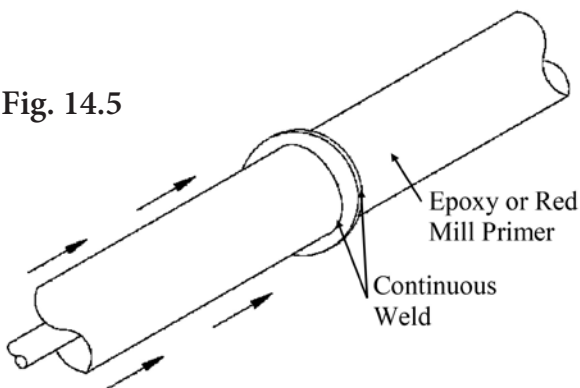

Fig. 14.5



**NOTE:** During the welding process do **NOT** use anti-splatter or any type of lubricant IF your system has leak detection. These materials can cause the leak detection to fail.

If the job requires a field applied anchor which needs to be applied in the middle of a length of pipe, the anchor must be split in order to apply it. **See figure 14.1**

Make a circumferential cut around the metal jacket at the point where the anchor will be installed. **See figure 14.2**

Slide the conduit jacket back. **See figure 14.3**

Apply the split anchor plate and weld both sides of the seam. Continuously weld the anchor plate to the carrier pipe and the conduit jacket. **See figure 14.4**

Slide the conduit jacket up to the anchor plate and make the circumferential welds on both sides of the anchor plate.

After air testing the outer jacket, clean all exposed steel and coat the anchor plate with epoxy or Red Mill to match the conduit jacket. **See figure 14.5**

## Section 15: Conduit Coating Testing

If required in the specifications, ROVANCO can supply a conduit coating tester for rental, credit card payment required. This tester will allow you to inspect the conduit coating for damaged areas. These damaged areas are called holidays. ROVANCO's Holiday Detectors are portable, all purpose electrical inspection instruments. They are adaptable for use on both large and small diameter conduit. The detector works on damp or dry surfaces.

A. Upon opening the carrying case, notice where the various components are located; repack them in the same manner when not in use. Then remove all components from the carrying case. Inspect them upon receipt. If damage has occurred, contact Rovanco. Check components against packing slip to be sure nothing is missing.

### B. Equipment assembly

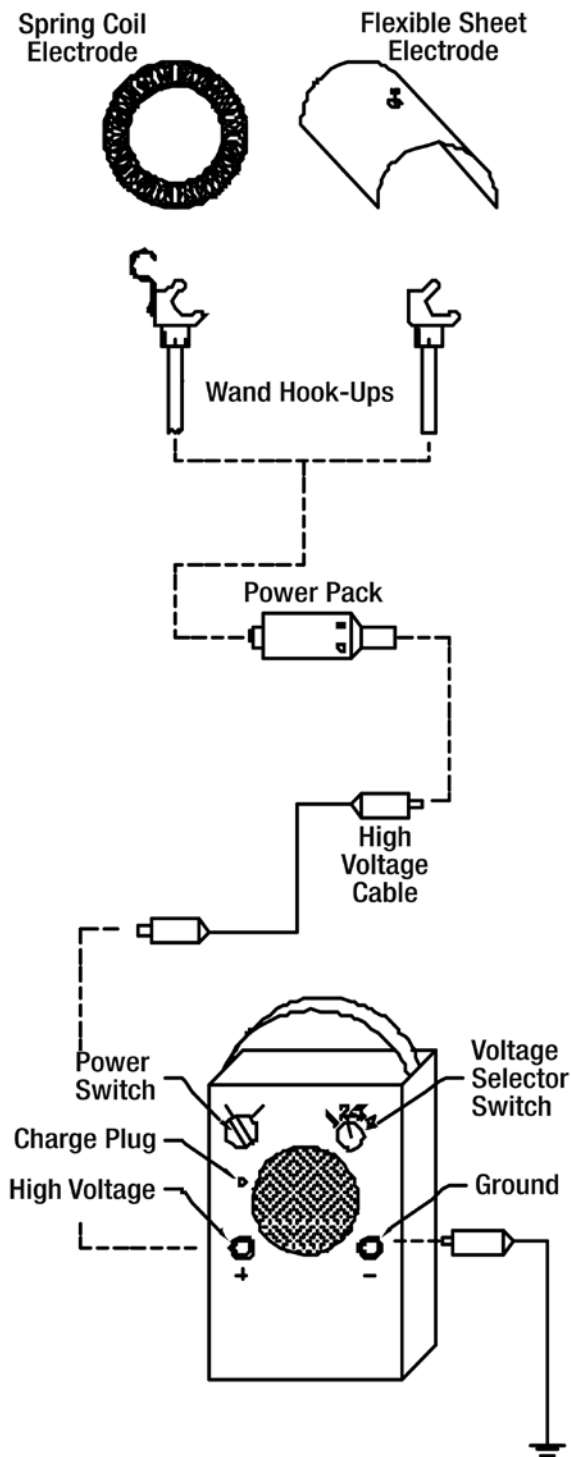

1. Ensure that the holiday detector ON-OFF switch is in the OFF position.
2. Using the battery tester, insert the test plug, on the battery tester, into the holiday detector charge plug receptacle. If the red LED indicator lights up, then the battery is okay, if not, then the battery needs to be recharged. Remove the tester from the battery.
3. Turn the output voltage selection switch on the detector to desired voltage. Voltages are listed on the individual power packs in ascending order, left-to-right. Use #4, 2,500 volts, for testing 20 mil Epoxy Coated Insul-8 Conduit. NOTE: Higher settings or voltages will damage the epoxy coating.
4. Insert leather belt into side loops on back of detector if belt-mounted method is to be used.
5. Uncoil the ground wire and plug connector into detector port marked ground. The ground wire will trail on bare earth or be attached to the conduit being tested.
6. Attach wand to the threaded male end of the power pack. Insert power pack cable (female connector) into male connector of power pack. Insert other end of power back cable into High Voltage port on detector.
7. Assemble the desired electrode and apply to the conduit. The electrode should always make an intimate contact with the surface to be inspected.
8. Turn the ON-OFF switch to the ON position. Note that when the switch is in the ON position, a buzzing sound may be heard coming from the detector. The detector is now ready to operate.

## A. Operating Methods

- 1. Grounding:** A good ground return system will always give the best and most reliable inspection. **The conduit must be grounded to earth** at some point. If individual lengths of conduit are to be inspected, each will have to be grounded separately.
- 2. Inspection:** The conduit should be inspected just prior to backfilling.
- 3. Inspection Speed:** The speed of the electrode travel over the conduit surface should be moderate, about 40 feet per minute. Moving the electrode at an excessive speed can result in an inaccurate inspection.

**Caution:** Do not test the same area twice, unless it is a repaired area, or let the electrode rest in one spot. Either may damage the epoxy coating on the conduit.

Fig. 15.1

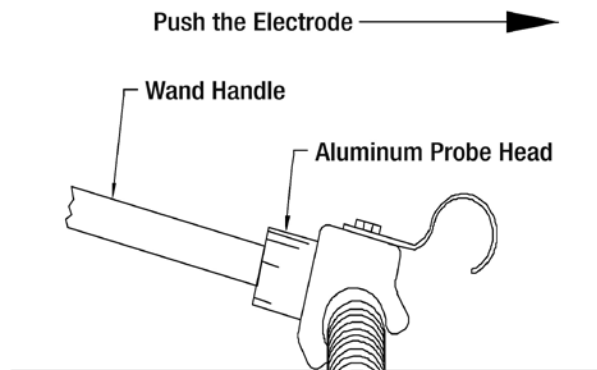

Fig. 15.2

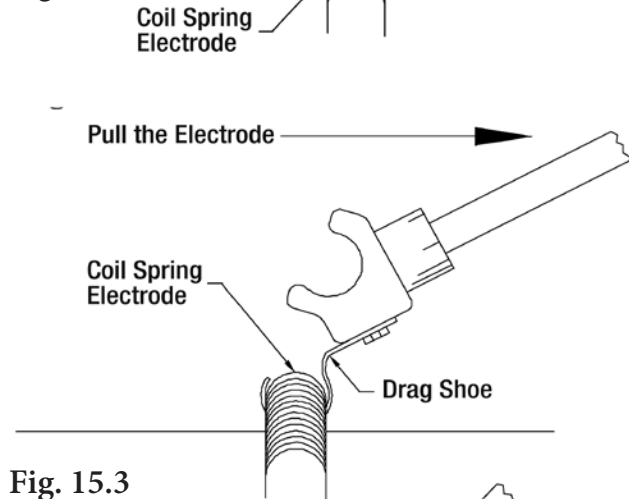
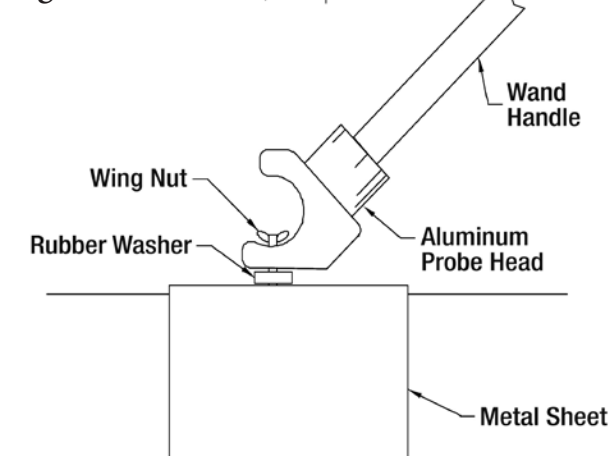

Fig. 15.3



## 4. Operating Checks:

- Occasional checks of the detector can be made if no holidays are being found. Move the inspection electrode to an area where there is bare metal. A spark and a signal should both occur.
- If the signal does not sound when the spark jumps, the ground return resistance is exceptionally high. For example, sandy, very dry soil or a large diameter pipe. To improve the ground, make a direct connection between the conduit metal under inspection, and the detector's ground wire.

## 5. Inspection Methods

- If the spring coil electrode is used, then use the standard cast aluminum probe head to push the coil spring electrode. This method of propelling the electrode is most effective for small pipe diameters. **See Figure 16.1.**
- For larger diameter pipes and particularly for over-the-ditch coating, use the drag shoe to pull the coil spring electrode. The shoe is attached onto the probe head with a cap screw that can be adjusted for lateral movement. A quick twisting motion will release the shoe from the spring. **See Figure 16.2.**
- If using the flexible metal/rubber sheet, first remove the drag shoe if necessary. Then attach as per **Figure 16.3**, making sure to insert the rubber washer, and bend the metal/rubber sheet to conform to the conduit outer-diameter.

1

## D. Instrument Servicing Repair

- 1. Cleaning:** Keep instrument clean and dry. Clean instrument case with a soft cloth dampened with kerosene or mineral spirits, then wipe dry. Do not use solvents such as lacquer thinner, MEK, etc.

## 2. Voltage output Checks:

### a. Low Output Voltage:

- Check position of voltage selection switch. It should be on #4, 2,500 volts.
- Check battery conditions using battery tester.
- Check for parted conductor in wand and ground wire.

### a. No Output Voltage:

- Check battery condition using battery tester.
- Check battery leads and the power switch for open circuit. Proper input current is .7 to .9 amps.
- Contact ROVANCO for further information.

## 3. False Signal Indication Check:

- Adjust the 4-position signal sensitivity switch through the porthole provided on the back panel in the belt recess.
- Electrical load conditions vary greatly through pipe sizes, coating thicknesses, and climatic conditions. The far counter-clockwise position, or Position 1, is the most signal sensitive. In most cases it is best to start out using Position 2.
- Check for parted connector in wand and ground wire.

## 4. No Signal with Spark Discharge:

- Check the position of the signal sensitivity switch.
- Adjust the signal sensitivity switch mentioned above.

## E. Battery Charging Instructions

**Caution:** The detector ON-OFF switch must be in OFF position while charging battery.

- Use battery charger provided. Part Number 031-5
- Recharge the battery in the instrument. Ventilation holes in front and back of the instrument case should be kept open.
- Plug charger into polarized receptacle of instrument. Note: The battery cannot be tested or charged when the instrument power switch is in the ON position.
- Plug AC power cord into any 120 volt 60 Hz outlet.
- Charge battery for 14 hours. Charge at temperatures above 45° F for best results.
- If charger pilot light is out it indicated that the charger is not operating.
  - Check the position of the power switch.
  - Check for a shorted battery cell.
- Disconnect charger from battery and AC outlet when not in use.

## F. Battery Maintenance Information

- When the instrument fails to operate in a normal manner, battery is fully discharged. Recharging before this occurs can extend the useful life of the battery considerably.
- Store at normal room temperature when not in use.
- If the battery has not been used for six months or more, recharge for 14 hours.

**Note:** If the detector fails to operate in a normal manner, the first step is to test the battery condition.



## Section 16: Repairs to Conduit

When damage to the coating has been located, it must be repaired before backfilling. Large areas of damage can be repaired with wrap-around shrink. Small areas should be covered with field applied epoxy (below ground) or red mil coating (above ground). ROVANCO has furnished field coating kits to cover any small holidays. Coat, let dry, and then retest the repaired area.

### A. Surface Preparation

The performance of any coating is dependent on the cleanliness of the surface. The coating must come in contact with the metal surface itself. Metal must be clean, dry, and free of loose rust, paint, oils, grease etc. Metal surfaces should be either blasted to NACE near-white metal, or cleaned with a surface grinder. Remove all oxidation from the area to be coated, and some of the coating around it. Bare metal surfaces should be coated as soon after cleaning as possible.

### B. Epoxy Repair Stick (below ground)

To apply the epoxy, pre-heat the repair area with a small propane torch. Continue to apply heat and rub the supplied epoxy repair stick, in a circular motion on the repair area until the desired mil thickness is achieved.

**See Figure 16.1**

**(above ground)** For red mil coating, apply supplied coating using a brush to approximately the same thickness as the rest of the coating on the spool.

### C. Handling Precautions

Avoid eye and skin contact; use protective clothing, gloves and eye protection. Avoid breathing vapors. In a non-ventilated area the operator should wear a paint mask. If coating is applied in an enclosed or confined area, operator should wear a positive air mask, and precautions should be taken to prevent the solvent vapor from reaching explosive limits. Remove contaminated clothing and launder before reuse.

Fig. 16.1

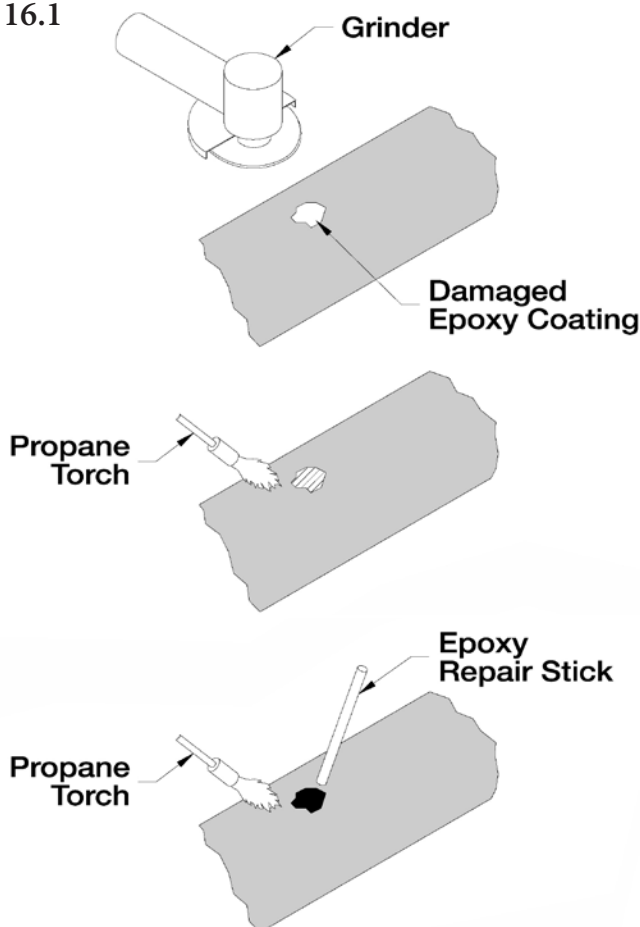

## Section 17: Drying Inner Conduit Casing

If the insulation in any section of the conduit should get wet, make note of the location. After the line is put in service and the internal pipe is heated from the boiler, force air through the air space with a portable compressor at not less than 3 cfm. Pump the air in through the vent at the high end of the system, and force it out of the drain at the low end, any water should come out first. Vent and drain plugs are located at end seals and gland seals. This will push out any water and force moisture out of the system.

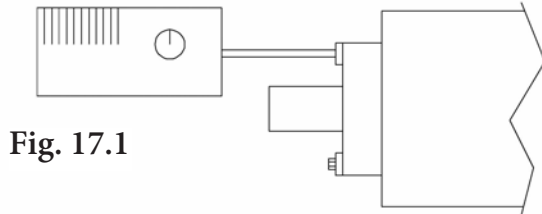

Fig. 17.1

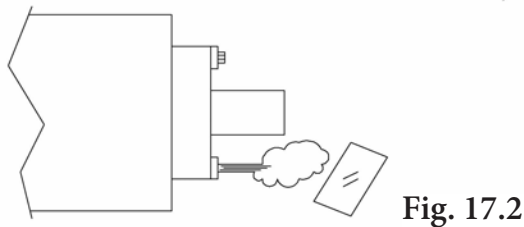

Fig. 17.2

**CAUTION: personnel should not stand in front of the drain during the drying process to avoid the possibility of scalding.**

The line is dry when you can not fog a cool mirror with the air coming out of the conduit at the low end drain plug. Drying time of insulation will vary with the amount of saturation, and the type, size, and thickness of the insulation. After the system is dry, pipe up the vents at the ends of the system with a goose neck and leave open for venting. Close the drain plugs at all ends of the pipe system. **See Figures 17.1 & 17.2**

## Section 18: Manhole & Building Entries

Fig. 18.1

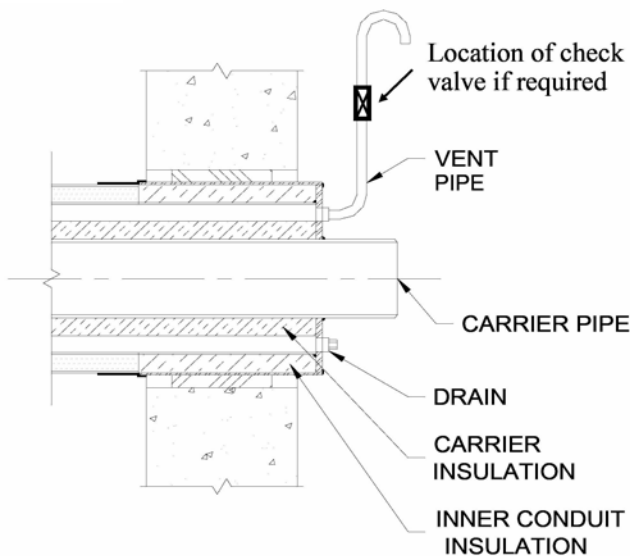

**See Figure 18.1** for the proper building entry or manhole entry detail. Also, as mentioned in the previous section, be sure before turning the job over to the owner that the vent on each end of the system is piped up above any potential water level and goose necked for venting. This is done so that water can not get high enough to enter the system. The vent piping and check valve are not supplied by ROVANCO. The drains should remain closed. It is recommended that at least 3" of the polyethylene jacket enter through the wall before our system ends.

**NOTE:** If the gooseneck cannot be installed above the potential high water mark, then a check valve must be installed in the vertical riser of the vent pipe.

It is mandatory all carrier pipe either be air or hydro tested per specifications prior to insulating and pouring thrust blocks around anchors or backfilling the system. Failure to comply with testing procedures will void warranty. Plastic carrier pipe must be hydro tested only, do not air test.

## Section 19: Pouring Concrete Anchors

ROVANCO recommends that the forms for the concrete anchor plates be done with sandbags or wood. These forms do not need to be stripped. The block should be 10" larger than the anchor plate, and 3' thick.

See Figure 19.1

Make sure that the block is large enough to anchor it to undisturbed earth. **AT NO TIME** should wood be touching the steel anchor. Contractor must make sure to have concrete completely encapsulate the anchor, especially underneath.

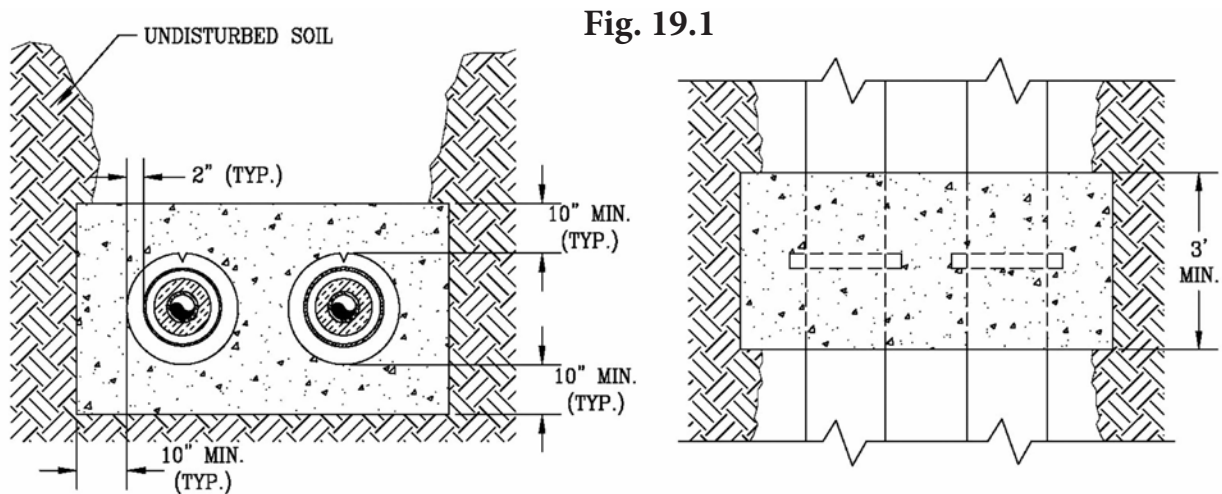

Fig. 19.1

## Section 20: Backfilling The System

The first foot of backfill must be free of frozen soil, rocks, or other debris. ROVANCO recommends the use of clean backfill material without sharp stones. If the project specifications require a specific backfill material, we recommend the installer follow the specification. Hand tamp in 6" layers to one foot above the conduit. After this, a mechanical tamper may be used. See Figure 20.1

**Note:** that you need 24" of cover tamped to 95% compaction to obtain H-20 traffic load conditions. However, this is not adequate for railroad crossings. In that case, contact our Engineering Department in Joliet, Illinois. If 24" is not obtainable, put 6" of 95% compacted sand above the pipe, and then a 4" to 6" reinforced concrete pad. The pad should overlap the edges of the trench by 1'. Then continue the backfilling to grade as usual.

See Figure 20.2

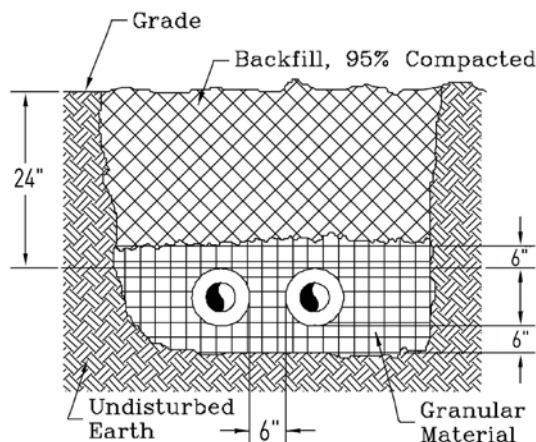

Fig. 20.1

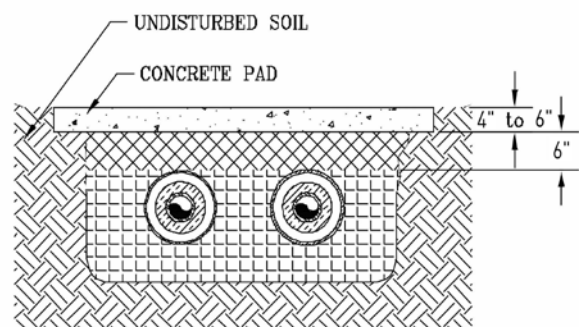
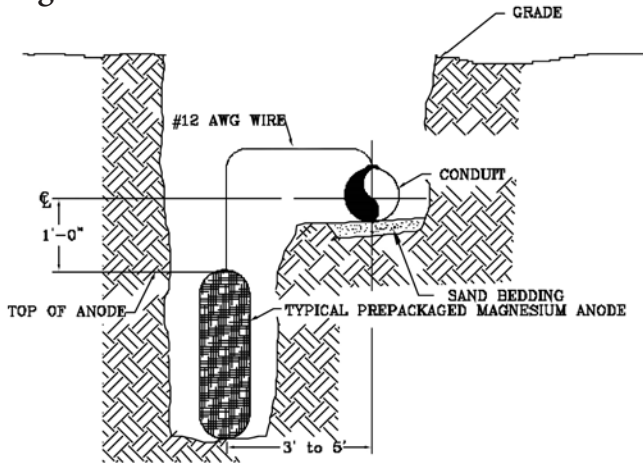

Fig. 20.2

## Section 21: Cathodic Protection

Fig. 21.1



To install a cathodic protection system to the conduit, first check the installation drawings for the locations of the anodes. Dig the holes for the anodes at the appropriate locations. The anodes should be 3' to 5' from the conduit, and about 1' lower than the conduit. The anode should be backfilled with 12" of native soil only. Next, string the wire, making sure that the #12 AWG wire is securely connected to the anode. Make sure to leave plenty of slack in the wires, especially in a test station.

See Figures 21.1, 21.2 and 21.4 for appropriate wiring diagrams and locations.

See Figure 21.3 for two pipe detail.

See Figure 21.4 for the test station wiring diagram.

To activate the anodes: the anodes must be saturated with a minimum of 5 gallons of water prior to backfilling. If anodes are not activated properly, the test results could be lower than required.

Fig. 21.2

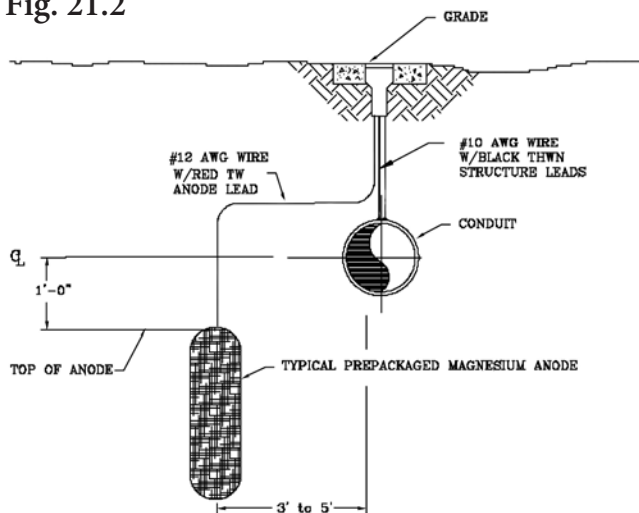

Fig. 21.3

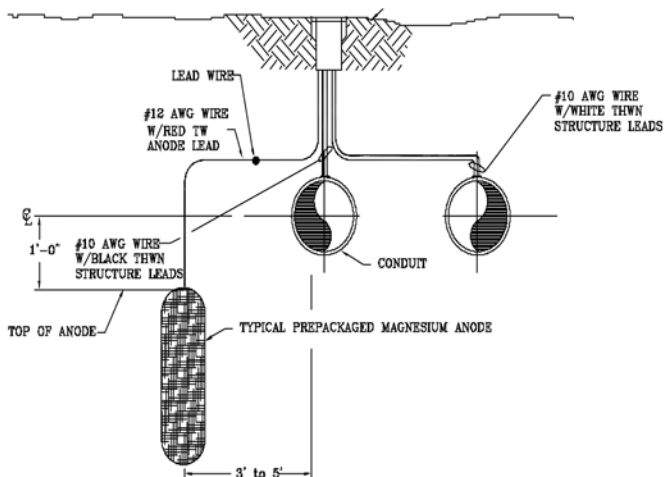

Fig. 21.4

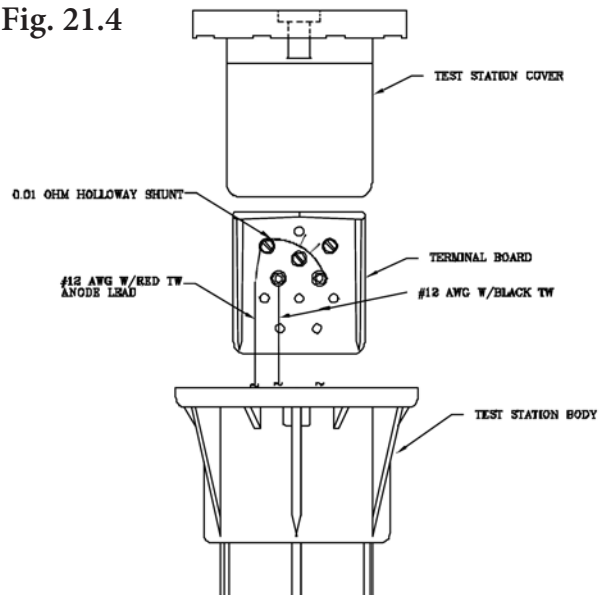

Fig. 21.5

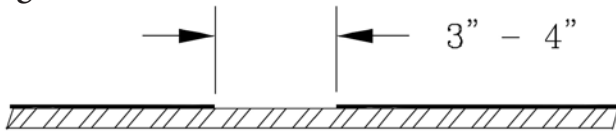

Fig. 21.6

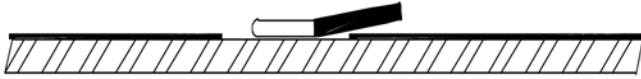

Fig. 21.7

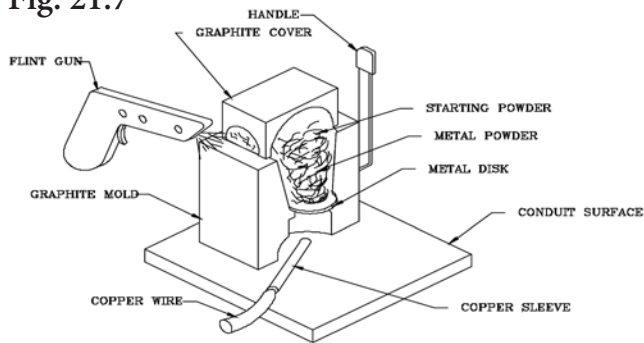

Fig. 21.8

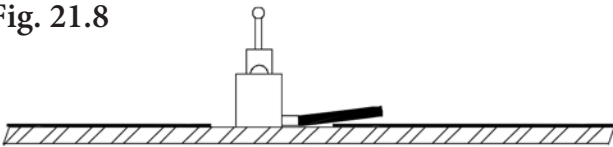

Fig. 21.9

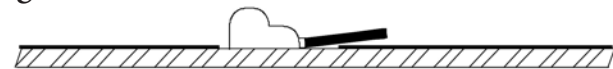

Fig. 21.10

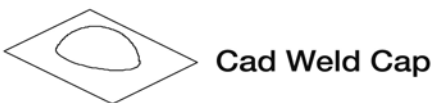
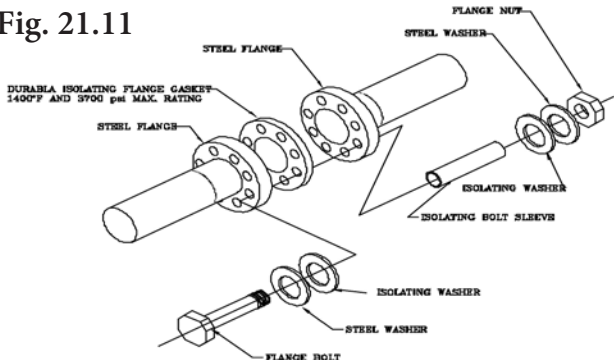

Fig. 21.11



NOTE: This detail is for informational purposes only. Rovanco is not supplying the materials shown.  
 NOTE: Isolating flange may be inserted at flanged valve location when available

**To attach the wire to conduit:**

1. Grind off the epoxy coating in a 2" or 2" square, down to white metal. Clean surface, and dry.  
**See Figure 21.5**
2. Strip 1" of insulation from the end of the wire, slip on a copper sleeve, and crimp it. Place the wire against bare conduit.  
**See Figure 21.6**
3. Prepare the welder by placing the metal disk in the bottom pocket of the cad welder. Be sure that two disks are not stuck together. Then open the powder cartridge, and dump out the powder into the pocket. The starting powder sticks in the base of the powder cartridge. Squeeze the base of the cartridge and dump out the starting powder on top of the regular powder. Close cover and place over wire.  
**See Figure 21.7**

**CAUTION:** Keep all unused powder cartridges away from sparks or open flame.

4. Hold welder firmly in place while making connection. Apply spark to side of welder.  
**See Figure 21.8**

**CAUTION:** Use protective eye wear. Powder will flare up when ignited.

5. After the weld cools, remove excess slag with a hammer.  
**See Figure 21.9**

6. Coat the connection with a coal tar compound. Make sure to fully coat the bare conduit, the inside of the cad weld cap, and the wire connection. Then place a cad weld cap over the connection.  
**See Figure 21.10**

It is the responsibility of the installing contractor to isolate the underground conduit system from the building or above grade piping, reinforcing steel in buildings, manhole walls, foundations, and any other metallic structures. The contractor must provide high temp isolating flange kits sufficient to isolate our pipe from pipe connected to ours. Flange sets when required will be provided by others. Refer to the installation drawings for isolating flange locations.  
**See Figure 21.11**

If the specifications allow, dielectric couplings or unions can be used in place of flanges for smaller pipes.

**Note: Flanges, flange gaskets, nuts, bolts, washers, and sleeves are not supplied by ROVANCO.**

## Section 22: Operation & Maintenance of Cathodic Protection Systems

**Introduction:** Corrosion is mitigated when the anodic corrosion current leaving a structure is appreciably reduced. Cathodic protection is a method of corrosion-control which minimizes anodic dis-solution by reducing the potential difference between the anodic and cathodic sites on a structure ex-posed to an electrolyte. Theoretically corrosion of the structure will be eliminated when the open circuit potentials of the cathodic sites are polarized to the open circuit potentials of the anodic regions of a structure. The entire structure becomes cathodic relative to an anode material installed within the structure's electrolyte.

There are generally two methods of applying cathodic protection. One of these methods uses anodes which are energized by an external DC power source. The second method makes use of galvanic anodes, which have an electrical difference in potential with respect to the structure to be protected. The anodes are fabricated from a material, such as magnesium or zinc, which is anodic with respect to the protected structure. The anodes are usually connected directly to the structure.

### Cathodic Protection System Maintenance

Cathodic protection systems must be properly maintained in order to operate effectively. Periodic inspecting and testing should be performed to insure continued beneficial performance and realization of the estimated design life of the system.

### Monthly Monitoring

Monitoring shall be referred to as a more frequent spot-check of the cathodic protection system. Monthly monitoring of the cathodic protection system is recommended at selected test locations. The following procedures should be followed during the monthly cathodic protection system inspection:

1. Read and record the structure-to-soil potentials at selected permanently installed test stations located along the underground structure. These test stations include:
  - Foreign line crossings
  - Bonds to foreign structures
  - Metallic casings a road crossings
  - Buried insulation joints
2. If the readings are acceptable, no further work is required. If the readings are not acceptable, a troubleshooting procedure will be required to resolve the problem, either performed by the owner or a qualified corrosion consultant contracted by the owner.

### Annual Maintenance

Maintenance shall be referred to as the detailed annual inspection and testing of the cathodic protection system. Annual maintenance should be performed by the owner of the system or a qualified corrosion consultant contracted by the owner.

A detailed annual survey should be conducted on the cathodically protected underground structures to include the following:

1. Measurement of the structure-to-soil potentials at all test stations and/or points where the structure is physically accessible.
2. Inspection of each accessible electrical isolator for effectiveness.
3. Measurement of current drained to or from the cathodically protected structure through existing electrical bonds.
4. Measurement of structure-to-electrolyte potential on intersecting structure and structures in the immediate vicinity.
5. Report any indications of interference current flow by appropriate notations. Interference currents are detectable by unusual uncycled fluctuations while observing potential measurements. Interference may tend to depress potentials of a metallic structure without the usual fluctuations. Any deviation in potentials to a less negative value for no apparent reasons should be noted and reported.

## Test Equipment

A portable high impedance voltmeter (20 mega-ohms minimum), a portable saturated copper/copper-sulfate reference electrode, assorted test leads, and a reel of insulated small gauge (No. 18 or No. 22 AWG) wire are required to perform testing of the cathodic protection system.

The voltmeter should be maintained in good operating condition and checked periodically for accuracy as recommended by the manufacturer.

## Cathodic Protection Criteria

The recommended practices established by the National Association of Corrosion Engineers (NACE) in Standard RO-01-69 (1983) and RP-02-85 list five criteria for cathodic protection of buried metallic structures. These criteria are as follows:

- A negative (cathodic) voltage of at least 0.85 volts as measured between the structure surface and saturated copper/copper-sulfate reference electrode contacting the electrolyte with protective current applied.
- A minimum negative (cathodic) voltage shift of 300 milli-volts produced by the application of protective current. The voltage shift is measured between the structure surface and a stable reference electrode contacting the electrolyte. This criterion of voltage shift applies to structures not in contact with dissimilar metals.
- A minimum (cathodic) polarization voltage shift of 100 milli-volts measured between the structure surface and a stable reference electrode contacting the electrolyte. This polarization voltage shift is to be determined by interrupting the protective current and measuring the polarization decay. When the current is initially interrupted, an immediate voltage shift will occur. The voltage reading after the immediate shift shall be used as the base reading from which to measure polarization decay.
- A structure-to-electrolyte voltage of at least as negative (cathodic) as that originally established at the beginning of the Tafel segment of the E-log-I curve. This structure-to-electrolyte voltage shall be measured between the structure surface and a stable reference electrode contacting the electrolyte at the same location where voltage measurements were taken to obtain the E-log-I curve.
- A net protective current from the electrolyte onto the structure surface as measured by and earth current technique applied at predetermined current discharge (anodic) points along the structure.

## Section 23: Operation and Maintenance of Steam Conduit

Annual: Remove the drain plugs to check for the presence of water in the air space yearly. When removing the drain plug, be alert for a possible steam flash. If water is found follow the repair procedure outlined below. The drain plugs must be replaced after the inspection to insure water does not inadvertently enter the air space from a flooded manhole or mechanical room.

**CAUTION:** Extreme caution must be exercised when entering steam manholes and opening vents and drains.

Also do an air test of the conduit yearly. Using an air compressor, pressurize the air space to 15 psig and hold for one (1) hour. If the pressure can not be maintained, see the repair procedure below.

### Repair

If a leak in the casing is found, it should be repaired, tested, coated, and backfilled as it was originally installed.

If a leak in the carrier pipe is found, at least a 1' section of pipe should be removed and replaced. The carrier pipe should then be hydrostatically tested at 1½ times it's operating pressure, not to exceed 500 psig. Repair the casing using a rolled sleeve, similar to the connector band used in assembling the field joints. Then coat the repaired connector band.

If insulation within the conduit becomes wet, then force ventilate the air space in the system at a rate of not less than 3 cubic feet per minute, and apply heat through the internal piping. Introduce the air through the system's high point vent, and force out the low point drain. Caution personnel regarding the possibility of a steam flash out of the low point drain while air is being forced through the system. Place a cool mirror at the exhaust point for a short time at appropriate intervals and position to indicate maximum fogging due to moisture. Continue ventilation until the mirror exhibits no visible fogging.

**System shut down:** If the system is shut down for any length of time, seal the system vents by plugging the goose neck or removing it and installing a plug. Purge with dry nitrogen before sealing system. The vents must be opened and the goose neck replaced before the system is turned on again. This will prevent moisture entry during shutdown.

### Manholes

Automatic sump pumps, if any, should be thoroughly inspected for proper operation annually. Steam traps, if any, should be routinely inspected and/or replaced, based upon the recommendations of the manufacturer. All flanges should be checked for leakage and tightened if necessary. Any evidence of groundwater leakage should be investigated and repaired. Gland seals, end seals, and the inside wall of prefabricated steel manholes should be routinely inspected for leaks and/or corrosion. Sand and repaint any corrosion to match the existing coating. Check valves routinely for leaks and repack when necessary.

Insulation and jacketing of internal piping and equipment should routinely be checked and replaced when necessary.

*If you have any questions about anything in this instruction manual, or have any difficulty in completing the work please feel free to contact ROVANCO's Customer Service Department at our main office in Joliet, Illinois (815) 741-6700.*

*Thank you once again for showing your confidence in ROVANCO by purchasing our High Temp Insul-8 products. We want you to know that we have a full line of pre-insulated and pre-fabricated piping systems for almost any temperature, pressure, or site condition.*

*If you are not familiar with our complete product line and you would like to know more about our product or would like to have our local Manufacturer's Representative call on you, call ROVANCO at (815) 741-6700, email us at [marketing@rovanco.com](mailto:marketing@rovanco.com), or visit us at [www.rovanco.com](http://www.rovanco.com).*



## Section 24: Parameters For Properly Installing & Operating Systems

Rovanco's pre-insulated and pre-fabricated products are carefully engineered to function as intended. If these products are properly installed, fully-tested, maintained and operated within the parameters for which they were designed, these systems should provide the user with years of trouble-free, efficient operation.

Refer to Rovanco's Installation Instruction(s) and the associated documentation from Rovanco's Engineering Department for important information and instructions that will carefully detail installation, testing, operating, and maintenance procedures. If needed, you are always welcome to contact Rovanco for assistance.

Failure to comply with the procedures as outlined in the Installation Instructions and Engineering support documentation could result in product damage, reduced product service life, costly repairs due to product failure, hazardous conditions which could result in injury to people, property and/or equipment. In addition, it will void Rovanco's warranty.

**If any Rovanco product does not perform as it is intended to, please inform Rovanco immediately.**

Some problems and their potential causes are listed below. Although this list is not all-inclusive, you may be able to find additional information in Rovanco's Installation Instruction(s) and/or the Engineering Department documentation.

### General Piping System Care:

- Wet insulation does not perform as intended and causes the premature failure of the system. Therefore, it is important the system's insulation is kept dry at all times. This includes during storage, installation and when system is operating.
- Our systems have been engineered to operate within a specific temperature & pressure range and under appropriate environmental conditions. Therefore, do not install or put our systems into service if these parameters are not within the product's specifications.
- If you find it is necessary to alter a Rovanco piping system, review the planned alterations with Rovanco or a qualified piping system designer before making any changes.
- Maintenance plays an important role in assuring you get the full service-life out of the system. Rovanco systems are designed to provide years of trouble-free operation, but changing conditions can affect that. So, systems should be inspected regularly to verify they are in good operating condition and functioning as intended. If repairs are required, make them promptly.

### Pre-Insulated Foam Systems:

- Piping systems must be kept dry. Moisture of any amount can corrode carrier pipe and prematurely breakdown insulation. This will shorten piping system service-life and/or prevent it from operating properly. Keep all piping system dry during storage, installation and when it is operating.
- Assure field joints are completed correctly. This includes the proper field insulating and enclosing the outer jacket in the joint area. Improper completion of field joints could result in water ingress effecting carrier pipe and/or insulation.
- Damage to jacketing must be repaired immediately. Failure to do so could allow moisture to reach the insulations and/or carrier pipe.
- When installing piping systems designed for underground use that require external expansion pads, you must assure these expansion pads are properly installed according to specifications. Proper installation will allow for associated thermal expansion. Improperly installed expansion pads will put unwanted stress on a piping system that could damage it.

## **Conduit & Containment Systems:**

- Moisture negatively affects a systems functionality and shortens its service-life. Moisture will corrode carrier, conduit & containment piping, leak detection or pull cables and it will degrade insulation. It is important that the air space in these systems is kept dry. If any type of moisture is detected, it must be dried immediately so system is returned to a dry state during installation and operation.
- A combination of moisture in the air space and high operating temperatures will accelerate the destruction of piping, its coating and any insulation. This can result in costly repairs, system damage and possibly system failure. Therefore, do not ever operate these systems under the negative conditions of moisture presence and high temperatures.
- Gland seals provide a seal against a service pipe while still allowing that service pipe to have axial movement. Therefore, it is important all gland seals are adjusted properly to these conditions are met and there is no binding of the service pipe.
- End seal vents and drain piping play an important role in keeping the air space dry. They allow the annular air space to vent and drain as well as prevent moisture ingress. So it is important end seal vents and drain piping is installed properly. This will allow them to function as intended.
- One important detail that will help keep the air space dry and drainable is to assure the piping system is installed with the proper slope so any moisture can drain as intended.

## **Systems Intended For Underground Installation:**

- Plan for adverse weather conditions prior to installation. If trenches gather water, they must be drained prior to the installation of the piping.
- Inspect all steel piping that will be buried prior to backfilling using a Holiday tester. Any holidays or damage to coating must be repaired in accordance with Rovanco's installation instructions prior to backfilling. Failure to repair voids or damage to coating will promote premature corrosion and effect system performance and length of service.
- Prior to backfilling, all carrier pipe, conduit and containment piping must be tested. If piping system integrity is not tested prior to backfilling, it will result in costly excavating and will not be Rovanco's responsibility.
- Cathodic protection system must be installed with thin-coated steel conduit or containment that will be direct buried. The cathodic protection will prevent the premature corrosion of thin-coated steel piping system.
- Line trench accordingly before piping installation. Backfill and compact post-installation in accordance with Rovanco's installation instructions. If these procedures are performed properly, it will help prevent damage to the system when the ground settles.
- Manholes must be kept dry at all times. Installing sump pumps, keeping end seals above water levels and not installing manholes in low points will help prevent water from draining into them.