

## **ROVANCO®** Piping Systems

20535 S.E. Frontage  
Joliet, IL 60431  
(815) 741-6700

# DEF and Heat Trace Above Ground Metal Jacketed Insul-8 Installation Instructions

INS-DEFHT

Revised 08/20/25

### **GENERAL**

This instruction manual will give you all the information needed in terms of techniques, tools, and accessories required to install ROVANCO Insul-8 Above Ground Metal Jacketed system. If you follow the instructions carefully, the end result will be a high quality, pressure testable containment piping system. Thank you for showing your confidence in ROVANCO by purchasing its products. We sincerely appreciate your business and we will provide you with quality products with a fair price and “great” service to deserve your future business. Please consult your local ROVANCO Manufacturer’s Representative for information about all of the products provided by ROVANCO.

### **INSPECTION**

Inspect all shipments on receipt. Examine all pipe and accessories as they are unloaded. Check to insure that every item on the packing list is received. Check the contents of the cartons to insure that the materials have arrived safely. Do not throw the cartons from the vehicle. Handle all materials carefully. Have the freight carrier make out a damage or short receipt if any discrepancies are found. Keep a signed copy of this receipt and notify ROVANCO immediately. All spool pieces shipped have individual part numbers labeled on each end. Refer to your packing list to be sure you have all spool pieces shown. With your paperwork, you will receive two copies of the installation drawings. These drawings will show the location of each piece of ROVANCO Insul-8 Above Ground system.

### **UNLOADING**

ROVANCO piping systems are manufactured to withstand normal field handling but, like any piping material, damage can occur from careless handling. The spool pieces should be unloaded from the truck using a cherry picker or other suitable equipment. Lift the pieces with nylon slings and spreader bars so as not to damage the piping, insulation, jacket, conduit or coating. Do not use chains or chokers in direct contact with the piping. **Do not drop spool pieces because this can damage the the piping, insulation, jacket, conduit or coating.**

### **STORAGE**

Use dunnage material under the pipe and between successive layers to protect the casing from foreign objects. Do not stack more than four layers high to avoid excessive weight on the bottom layer. Prior to installation cover the pipe ends with a white tarp or white visqueen to keep out water, excessive dust and debris. If the pipe will be stockpiled in direct sunlight or at temperatures exceeding 90°F, cover the entire system with a white tarp or white

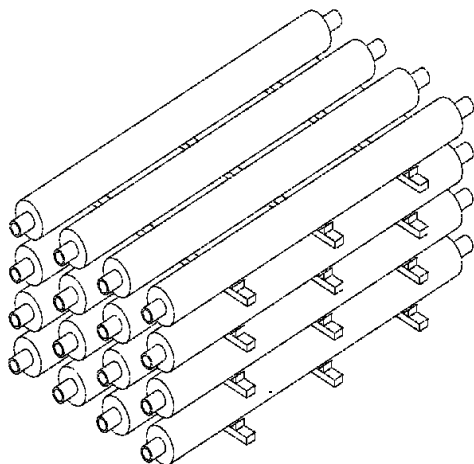

visqueen. Do not use opaque, clear or any other color other than white. If these steps are not taken, warranty will be void. There should be a layer of wood dunnage between the pipe and visqueen. Cartons of material (i.e. glue, foam kits, fiberglass ad-hesives, etc.) should be stored in a dry area at 60° to 80°F. Liquid foam has a shelf life of 6 months after delivery. Freezing or high temperatures may affect the product’s ability to perform their functions. IF these steps are not taken, warranty will be void.

### **TESTING**

All carrier pipe must be hydro tested prior to insulating, pouring thrust blocks or backfilling the system. Failure to comply with testing procedures will void warranty.

<b>TABLE OF CONTENTS</b>		<b>PAGE</b>
Section 1	Insulation Material List	3
Section 2	Field Alteration of Pipe	3
Section 3	Insulating Joints	4
Section 4	Insulating Fittings	5
Section 5	Insulation and Jacketing of Tees and Reducing Tees Banding	7
Section 6	Instructions	9
Section 7	Prepping & Fittings	10
Section 8	Heat Trace Instructions	11-35
Section 9	Operation & Maintenance	36
Section 10	Parameters for Properly Installing & Operating Systems	37-38

**Important: Read all instructions completely before proceeding with the installation**

**Metal Jacketed Above Ground Systems**

Rovanco metal fitting cover system is designed to provide a weather tight protective closure for the insulated fittings, such as 90° and 45° changes of direction as well as tees.

We provide the insulation, metal fitting covers, aluminum strapping, and clips.

Rovanco’s fitting covers are packed separately from the insulation sections and are individually labeled to indicate the jacket size they fit. The insulation is packed in separate containers separated to indicate the pipe size and insulation thickness unless the mineral wool or fiberglass is supplied as bulk batts. The straight sections of insulation are provided in three foot lengths (see Photo 1). They are field cut to fit by the installing contractor. Insulation sections are temporarily held in place by filament or box tape (see Photo 2), wire, duct tape, or other suitable means, supplied by the installing contractor.

The metal elbow fitting covers are provided in four sections, two sleeves and two stamped elbow pieces. Tee fittings are supplied as five pieces, three sleeves and two tee half pieces.

**DEF — Above Ground**

If the operating temperature is above the ambient temperature, any moisture that might be inside the metal jacket will be driven out. If the system is going to be installed out doors or indoors in an area where it could be subjected to “wash-down” such as food processing facility, the top half of the circumferential seams should be sealed with silicone sealant. The bottom half is not sealed to allow any moisture that may be in the insulation system to exit. Seal circumferential seams on the top and the sides. Also seal any longitudinal seam where rain water can penetrate.

**Testing**

All carrier pipe must either be air or hydro tested per specifications prior to insulating, pouring thrust blocks around anchors or backfilling the system. Failure to comply with testing procedures will void warranty. Plastic carrier pipe must be hydro tested only, do not air test.

ROVANCO’s products and processes are covered under various US patents, including, but not limited to 4,084,842 - 4,484,386 - 4,221,405 - 3,793,411.

Insul-8 and ROVANCO are Federally Registered trademarks of ROVANCO Piping Systems, Inc.

**For Leak Detection Installation Instructions, contact Rovanco for INS-RAT**

## SECTION 1 - INSULATION MATERIAL LIST

Insul-8 pipe joints and fittings are easily field insulated. The following lists are some of the tools and materials you will need to install the pipe.

### Materials (Supplied by Rovanco)

1. Insulation for Fittings and Straight Joints—Rovanco uses mineral wool or fiberglass insulation for the field insulated fittings and straight joints because the material is 1. rated for high temperature, 2. the material is flexible and compressible, so it can be packed into the joint area and will expand to fill cracks as the pipes move due to expansion and contraction, 3. the material is readily available, and 4. the material has been proven in the industry for over 40 years with many installers experienced with installing it.
2. Metal fitting covers
3. Pre-Cut Split Sleeves for Straight Joints and Fittings
4. Aluminum Banding and Clips

### Materials (Supplied by Contractor)

1. Duct or Filament Tape
2. Sheet Metal Screws (if screws are used)
3. Pop Rivets & Tool (if pop riveting is required)
4. Silicone Sealant

## SECTION 2 - FIELD ALTERATION OF PIPE

**Fig. 2.1**

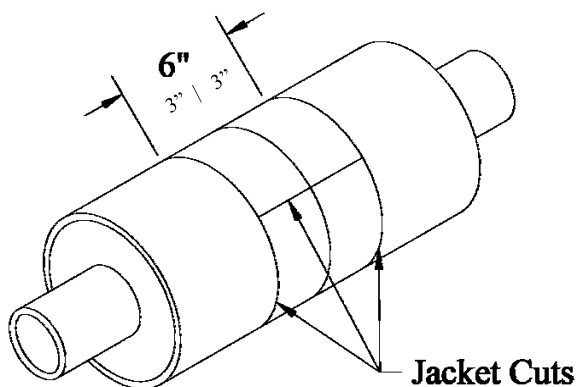

1. Each length of Insul-8 piping comes with approximately three inches of pipe exposed at each end to allow for joining.
2. Select the point at which pipe is to be cut and mark it on the casing.
3. Measure three inches on both sides of that point and draw lines using a wrap around. Make two circumferential cuts on the casing using a saber saw, reciprocal saw, or similar tool. See Figure 2.1
4. Make a longitudinal cut on one side of the pipe jacket between the two circumferential cuts. Peel away the casing and clean off foam so the carrier pipe is exposed.
5. Using a wire brush or scraper, remove all foam residue from the exposed pipe. Cut the carrier pipe to length and dress the ends appropriately.

## SECTION 3—INSULATING JOINTS

**Rovanco** uses mineral wool or fiberglass for the field insulated fittings and straight joints because the material is 1. rated for high temperature, 2. the material is flexible and compressible, so it can be packed into the joint area and will expand to fill cracks as the pipes move due to expansion and contraction, 3. the material is readily available, and 4. the material has been proven in the industry for over 40 years with many installers experienced with installing it.

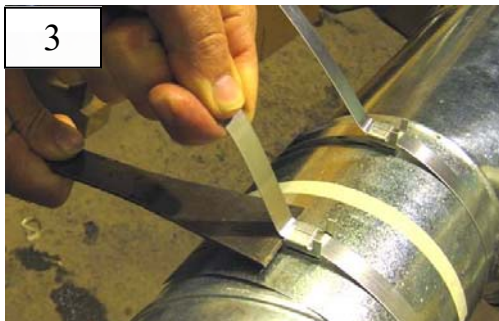

1. It is recommended that a carrier pipe be joined per project specifications and industry standards, and that a successful hydrostatic test per job specifications be completed before starting to insulate joint areas. At this time, Rovanco recommends that the pex tube for the heat trace system may be cut back flush with the foam insulation. Use a thin piece of metal to slide between the pex and the carrier pipe while cutting the pex tube. This will help protect the carrier pipe from damage. All heat trace cables must be pulled and tested. Ensure that the heat trace maintains contact with the carrier and fitting throughout the exposed length.
2. Insulation is provided as pre-molded insulation. The insulation will have to be notched to accommodate the carrier coupling. See Photo 1. Measure the joint opening and cut the insulation to length. It should be a snug fit. Secure the insulation in place with box tape. The tape is just to hold the insulation in place while working. See Photo 2.
3. Center the Galvanized sleeve over the joint. Rovanco recommends that the two circumferential and one longitudinal seam be sealed with caulk under the sleeve. Be sure that the top of the longitudinal seam overlaps the bottom for water shed effect, apply tape to hold in place. Install banding and clips to secure the sleeve in place. See Photo 3.
4. Secure all banding and trim excess as required. Remove the tape that was used to hold the sleeve in place. See Photo 4.

## SECTION 4—INSULATING FITTINGS

6



7



8



9



1. It is recommended that a carrier pipe be joined per project specifications and industry standards, and that a successful hydrostatic test per job specifications be completed before starting to insulate joint areas. Make the carrier pipe fitting joint as required. At this time, the pex tube for the heat trace system should be cut back, flush with the foam insulation.  
  
All heat trace cables must be pulled and tested. Ensure that the heat trace has enough slack at the elbow to maintain contact with the carrier and fitting throughout the exposed length. See Photo 6.
3. Insulation for standard 90° & 45° fittings is provided as pre-molded insulation. Position the insulation elbow in place and secure the insulation in place with box tape. The tape is just to hold the insulation in place while working. See Photo 7.
4. The three to four inches of insulation for the straight pipe on either side of the fitting has to be cut from the pieces saved from the straight joints and applied snugly, the same as would be done for straight joints. Secure the insulation in place with box tape. See Photo 7.
5. Place the 5” long sleeves on both sides of the fitting. Align the outer edge of the sleeve approximately 1 1/2” from the end of the foam jacket. Make sure the seam is made by the top overlapping the bottom. Seal the top half of the sleeves and the sleeve to the jacket with silicone caulk, when required. Secure in place with tape, while working. See Photo 8.
6. Once sleeves are in place on both sides of the fitting, secure with an aluminum band at the outer edge of each sleeve. See Photo 9.
7. Install the fitting cover. Start by positioning the bottom half first. See Photo 10. Make sure that the top half overlaps the bottom. Tape can be used to hold the cover in place, if needed. See Photo 11. Seal the cover seams and the seams to the sleeves with silicone caulk, when required.

10



11



12



8. Install an aluminum band at each end of the fitting cover. The bands should be approximately 1" from each end. Install one to two in the middle as the fitting shape allows. See Photo 12 for the completed fitting cover.

13



14



15



16



**SECTION 5 - INSULATION AND JACKETING OF TEES& REDUCING TEES**

1. It is recommended that a carrier pipe be joined per project specifications and industry standards, and that a successful hydrostatic test per job specifications be completed before starting to insulate joint areas. Make the carrier pipe fitting joint as required. At this time, the pex tube for the heat trace system should be cut back flush with the foam insulation.
2. All heat trace cables must be pulled and tested. Ensure that the heat trace has enough slack at the tee to maintain contact with the carrier and fitting throughout the exposed length. See Photo 13.
3. Insulation for tee fittings is provided as batt mineral wool or fiberglass insulation . Position the insulation in place and secure the insulation in place with box tape. . The tape is just to hold the insulation in place while working. See Photo 14.
4. Place the 5” long sleeves on both sides of the fitting. Align the outer edge of the sleeve approximately 1 1/2” from the end of the foam jacket. Make sure the seam is made by the top overlapping the bottom. Seal the top half of the sleeves and the sleeve to the jacket with silicone caulk, when required. Secure in place with tape, while working. See Photo 15.
5. Once sleeves are in place on all three sides of the fitting, secure with an aluminum band at the outer edge of each sleeve. See Photo 16.
6. Place the tee fitting cover over the fitting and mark the 6” main ends of the fitting cover. See Photo 17. (The 4” branch does not need to be marked.)
7. Apply a 2” wide Alumaguard strip, shiny side up, on both 6” sleeves. See Photo 18. The

17



18



19



20



21



Alumaguard strips should be approximately 1/2" beyond the cover end marks from step 6. See Photo 19.

8. Install the fitting cover. Start by positioning the bottom half first. Make sure that the top half overlaps the bottom. Tape can be used to hold the cover in place, if needed. See Photo 20. Seal cover seams and the 4" branch to the sleeve with silicone caulk, when required.
9. Install 1 band on each leg of the tee cover and remove any tape used during assembly. See Photo 21.

22



23



24



25



## **SECTION 6—INSULATING BANDING**

1. The banding is to secure the cover in a snug position. Installing the aluminum banding can be accomplished with a rigid 2" putty knife and a simple pair of pliers. Pre-measure the circumference of the pipe and cut your banding accordingly. Leave an extra eight to ten inches to make it easy to work with. See Photo 22. Slide the clip on band as shown bringing the end of the banding around the sleeve and again through the clip so that it forms a loop. Now bend the banding end back so that it can't be pulled out easily.
2. Grip the loose end of the banding with pliers, and slide the putty knife against the clip, between the loose end and the banding going around the sleeve. See Photo 23. Pull the banding tight.
3. Once the banding is tight around the sleeve, bend the loose end tight over the top of the clip. See Photo 24.
4. Bend the two tabs on the clip over the banding to secure the banding in place. See Photo 25.
5. Trim excess banding as required. Repeat for all banding locations.

## **SECTION 7: PREPPING AND FITTINGS**

Although Rovanco Piping Systems does not supply the Electro Fusion Welding Processor we recommend that all parties involved are properly trained and certified by a factory trained technician. Many things can go wrong in the fusion of the fitting if not properly trained. All pipe and fittings need to be free of moisture, dirt and other contaminants. The pipe needs to be properly scraped at the proper insertion and wiped down with alcohol. Pipe needs to be completely inserted into the fitting per instructions and perfectly aligned. Rovanco recommends that the contractor refer to the Electro Fusion Processor welding instructions for generator sizing. Please follow all guidelines and instructions furnished by the supplier of the Electro Fusion Processor your will be using to insure proper weld/fusion.

## SECTION 8: HEAT TRACE CABLE INSTRUCTIONS

### 2 Installation Guidelines

#### 2.1 Heating Cable Storage

- Store the heating cable in a clean, dry location. Temperature range: 0°F (-18°C) to 140°F (60°C).
- Protect the heating cable from mechanical damage.

#### 2.2 Pre-Installation Checks

##### Check materials received

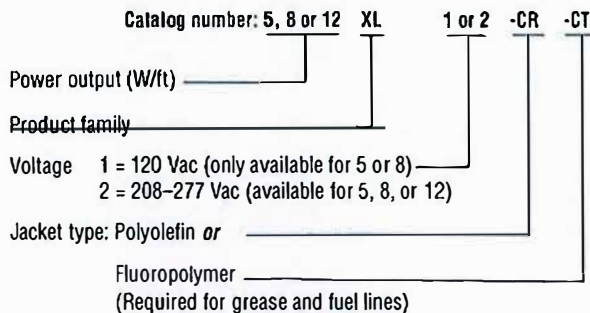

Figure 1: XL-Trace catalog number

- Review the heating cable design and compare the list of materials to the catalog numbers of the heating cables and connection kits received to confirm that the proper materials are on site. The heating cable type is printed on its jacket.
- Ensure that the service voltage available is correct for the XL-Trace heating cable selection.
- Inspect the heating cable and connection kits to ensure there is no in-transit damage.
- Verify the system design does not exceed the maximum exposure temperature of the heating cable 5XL/8XL: 150°F (65°C) 12XL: 185°F (85°C)
- Verify that the heating cable jackets are not damaged by conducting the insulation resistance test (refer to Section 7) on each reel of heating cable. Do not power the heating cable when it's on the reel.

##### Check piping to be traced

- Make sure all mechanical pipe testing (i.e. hydrostatic testing/purging) is complete and the system has been cleared by the client for tracing.

### 2 Installation Guidelines

- Walk the system and plan the routing of the heating cable on the pipe.
- Inspect the piping and remove any burrs, rough surfaces, or sharp edges.

#### 2.3 Heating Cable Installation

Minimum installation temperature of: 0°F (-18°C).

Heating cable installation involves three basic steps:

1. Paying out the heating cable
2. Attaching the heating cable to the pipe
3. Wrapping heat sinks

##### Paying out the heating cable

Mount the reel on a holder and place it near either end of the pipe run to be traced. Use a reel holder that pays out smoothly with little tension as shown in Figure 2. Avoid jerking the heating cable while pulling.

Pay out the heating cable and loosely string it along the pipe, making sure the heating cable is always next to the pipe when crossing obstacles. If the heating cable is on the wrong side of a crossing pipe or I-beam, you will have to reinstall it or cut and splice it.

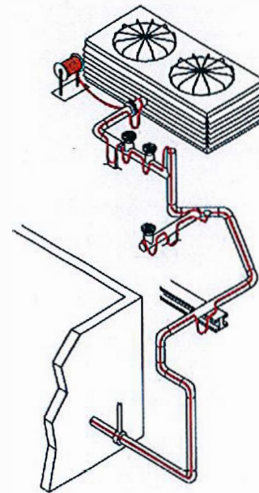

Figure 2: Paying out the heating cable

## 2

### Installation Guidelines

**When paying out the heating cable, AVOID:**

- Sharp edges
- Excessive pulling force or jerking
- Kinking or crushing
- Walking on or running over the heating cable with equipment

**⚠ WARNING: Fire and shock hazard. Do not install damaged heating cable. Connection kits and heating cable ends must be kept dry before and during installation.**

#### **Attaching the heating cable**

Once the heating cable has been run for the entire section, begin fastening it to the pipe. Start at the end and work toward the reel. The additional heating cable required for valves and other heat sinks is shown in Tables 1 and 2. Refer to pages 18–19 for the additional heating cable required for connection kits. The heating cable may be installed in single or in multiple runs as required by the design.

## 2

### Installation Guidelines

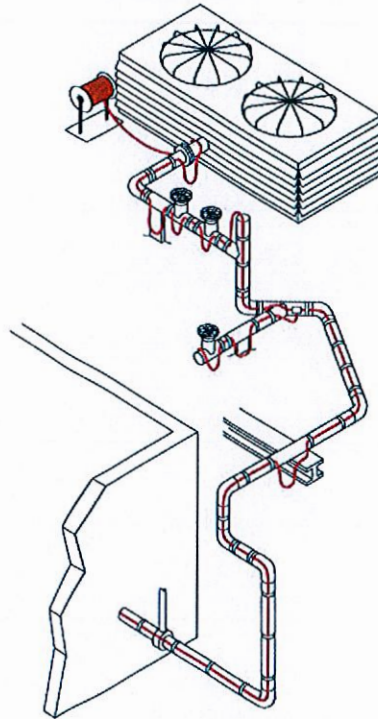

**Figure 3: Attaching the heating cable**

## 2 Installation Guidelines

**Table 1: Additional Heating Cable for Valves**

Pipe diameter (IPS)	Heating cable in feet (meters)
1/2	0.8 (0.24)
3/4	1.3 (0.4)
1	2.0 (0.6)
1-1/4	3.3 (1.1)
1-1/2	4.3 (1.3)
2	4.3 (1.3)
3	4.3 (1.3)
4	4.3 (1.3)
6	5.0 (1.5)
8	5.0 (1.5)
10	5.6 (1.7)
12	5.9 (1.9)
14	7.3 (2.2)
18	9.4 (2.9)
20	10.5 (3.2)

**Table 2: Additional Heating Cable for Pipe Supports and Flanges**

Support	Additional heating cable
Pipe hangers (insulated)	No additional heating cable
Pipe hangers noninsulated and U-bolt supports	Add 2x pipe diameter
Welded support shoes	Add 3x the length of the shoe
<b>Flanges</b>	Add 2x pipe diameter

**Note:** For applications where more than one heating cable is required per foot of pipe, this correction factor applies for each heating cable run.

## 2 Installation Guidelines

- Run insulation through the pipe hanger ensuring that the pipe is not resting on the heater.

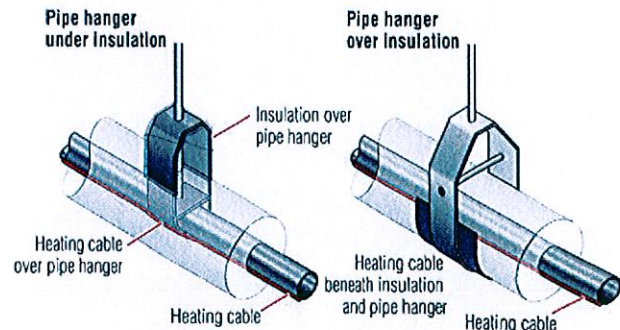

**Figure 4: Pipe hanger with heating cable**

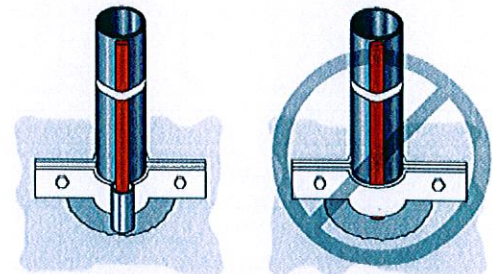

**Figure 5: Single pipe floor penetration**

- When making floor or wall penetrations, make sure the hole is large enough to accommodate the pipe and the thermal insulation. When sealing around pipes at floor penetrations, avoid damaging or cutting the heating cable, or pinching it between the pipe and the concrete.

## 2

### Installation Guidelines

- The heating cable must not be embedded directly in the sealing material; the pipe should have thermal insulation over it (if allowed by local codes) or the heating cable should be run through the penetration in a tube or conduit. If the conduit must be sealed, use a pliable fire-resistant material (Dow Corning Fire Stop, 3M Fire Barrier, or T&B Flame-Safe) that can be removed if necessary.

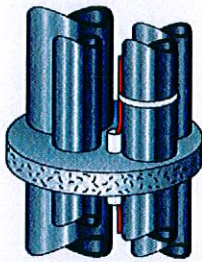

Figure 6: Multiple pipe floor penetration

- On vertical piping groups, run the heating cable along the inside of the pipe close to other pipes so it will not be damaged if the pipe hits the side of the floor penetration. Run the heating cable over the outside of the pipe support. Do not clamp the heating cable to the pipe with the pipe support.
- In high-rise construction it may be necessary to install the XL-Trace system 10 or 12 floors at a time to fit into the construction schedule. If so, the end of the heating cable should be sealed with a RayClick-E end seal and placed in an accessible location. This allows testing of one part of the heating cable at a time, and allows splicing it to another section when the system is complete.
- When XL-Trace is installed behind walls, the power connection kit must be accessible.

Whenever possible, position the heating cable on the lower section of the pipe as shown in Figure 7 to protect it from damage.

## 2

### Installation Guidelines

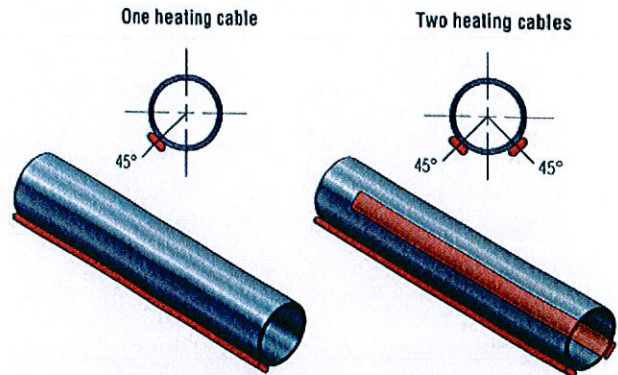

Figure 7: Positioning the heating cable

#### Securing the heating cable

**⚠ WARNING:** Damage to the heating cable can cause electrical arcing or fire. Do not use metal attachments such as pipe straps or tie wire. Use only Tyco Thermal Controls-approved tapes or plastic cable ties.

**⚠ Important:** Before taping the heating cable to the pipe, make sure all heat-tracing allowances for flanges, valves, supports, and other connection kits have been verified.

Use one of the following attachment methods to secure the heating cable onto the pipe: GT-66 or GS-54 glass cloth tape, AT-180 aluminum tape, or plastic cable ties.

#### Glass cloth adhesive tape

- GT-66 (66-foot roll) general-purpose tape for installation at 40°F (4°C) and above. Apply at 1-foot intervals.
- GS-54 (54-foot roll) general-purpose tape for installation below 40°F (4°C). Apply at 1-foot intervals.

#### AT-180 aluminum tape

- Required for plastic pipe applications to ensure proper power output of heating cable.
- Tape lengthwise over the heating cable as required by the design drawing or specification (see Figure 8).
- Recommended for heat-tracing pump bodies or odd-shaped equipment, or as called out in the design drawing as a heat-transfer aid.
- Install at temperatures above 32°F (0°C).

## 2 Installation Guidelines

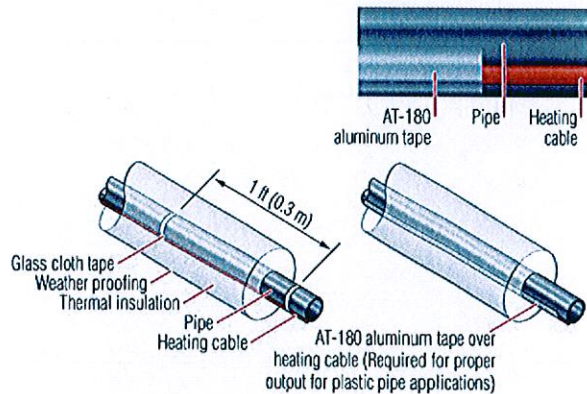

Figure 8: Attaching the heating cable

### Cable ties

- Recommended in applications where the pipe surface prevents proper tape adhesion.
- Use plastic cable ties only.
- Cable ties must be hand-tightened only to prevent damage to heating cable!

### Bending/Crossing/Cutting the Heating Cable

#### Bending the heating cable

When positioning the heating cable on the pipe, do not bend tighter than 1/2' radius. The heating cable does not bend easily in the flat plane. Do not force such a bend, as the heating cable will be damaged.

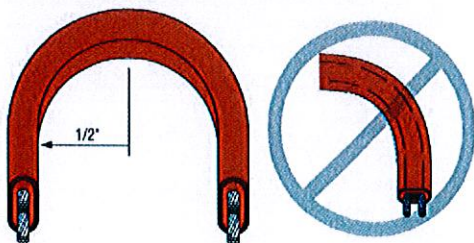

Figure 9: Bending technique

## 2 Installation Guidelines

### Crossing the heating cable

XL-Trace heating cables are self-regulating and may be overlapped whenever necessary without overheating or burning out.

### Cutting the heating cable

Cut the heating cable to the desired length after it is attached to the pipe. XL-Trace can be cut to length without affecting the heat output per foot.

### Wrapping the Heat Sinks

Once the straight sections are secured the heating cable can be secured to the heat sinks. Attach the heating cable to the heat sinks according to Figure 10 below. The length of heating cable installed is determined in the design.

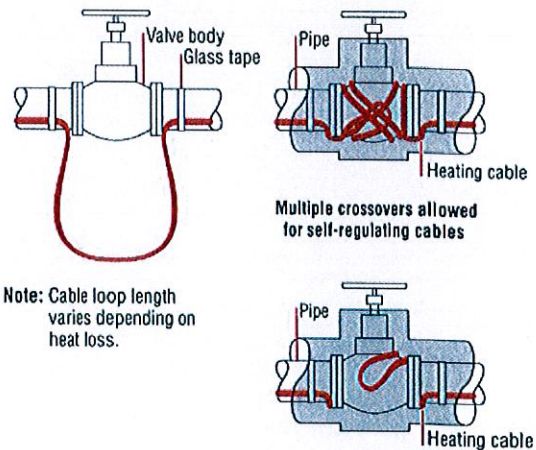

Figure 10: Valve

## 2 Installation Guidelines

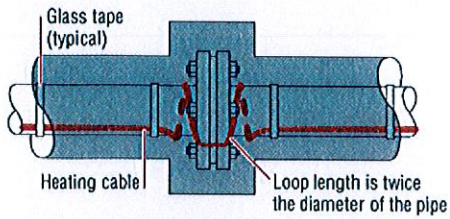

Figure 11: Flange

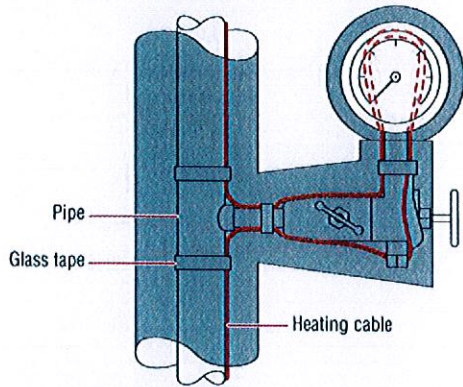

Figure 12: Pressure gauge

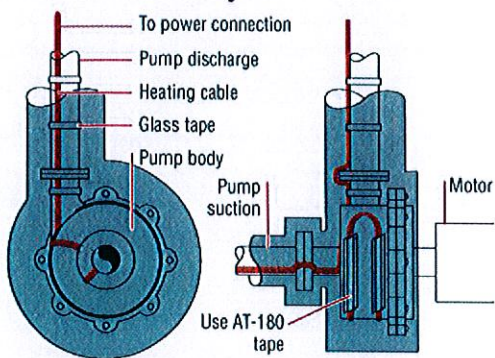

Figure 13: Split case centrifugal pump

## 2 Installation Guidelines

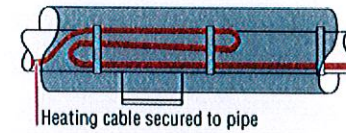
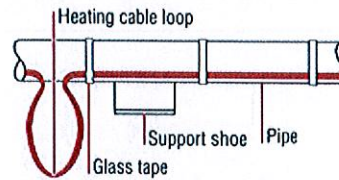

Figure 14: Pipe support shoe

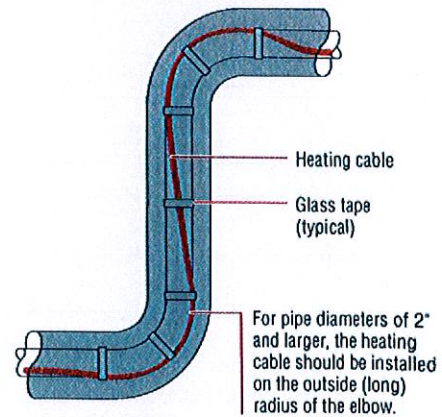

Figure 15: Elbow

## 2 Installation Guidelines

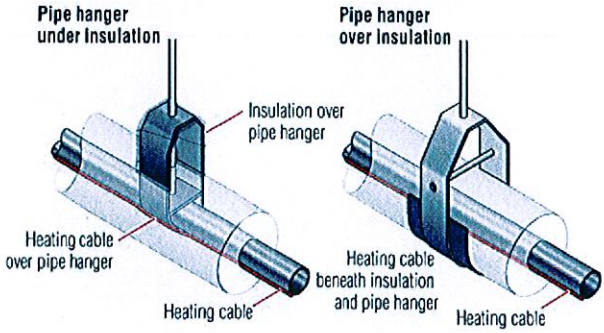

Figure 16: Pipe hanger

## 2 Installation Guidelines

### 2.4 Heating Cable Connections

#### General Requirements

All XL-Trace systems require a power connection and end seal kit. Splice and tee kits are used as required. Use Table 3 (for aboveground applications) and Table 4 (for below-ground applications) to select the appropriate connection kits.

When practical, mount connection kits on top of the pipe. Electrical conduit leading to power connection kits must have low-point drains installed to avoid condensation entry into the heating system. All heating cable connections must be mounted above grade level.

If your design has an exposure temperature >150°F (65°C) but < 185°F (85°C), install all connections kits off the pipe.

**⚠ WARNING:** Connection kit approvals and performance are based on the use of specified parts only. Do not use substitute parts or vinyl electrical tape. Follow installation instructions provided with each kit.

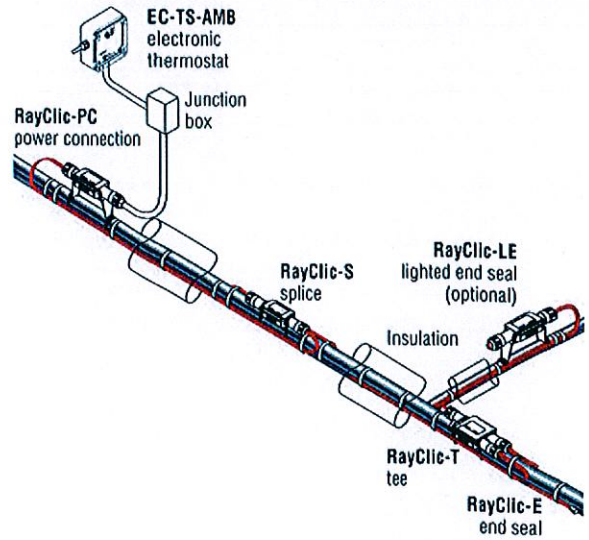



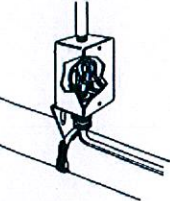

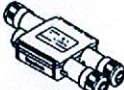

Figure 17: Aboveground XL-Trace System

# 2

## Installation Guidelines

Use Table 3 for general aboveground piping, sprinkler piping, and grease and fuel lines. Allow extra heating cable for ease of connection kit installation.



**Table 3: Connection Kits for General Aboveground Piping**

Catalog number	Description	Heating cable allowance <sup>1</sup>
 RayClic-PC <sup>2,3</sup>	Power connection and end seal kit; use 1 per circuit <b>Standard pkg: 1</b>	2 ft (0.6 m)
 FTC-P <sup>4,5</sup>	Power connection and end seal kit; use 1 per circuit <b>Standard pkg: 1</b> <i>Junction box not included</i>	2 ft (0.6 m)
 RayClic-S <sup>2,3,6</sup>	Splice used to join two sections of heating cable <b>Standard pkg: 1</b>	2 ft (0.6 m)
 RayClic-T <sup>2,6</sup>	Tee kit with end seal; use as needed for pipe branches <b>Standard pkg: 1</b>	2 ft (0.6 m)
 RayClic-LE	Alternate lighted end seal <b>Standard pkg: 1</b>	2 ft (0.6 m)

# 2

## Installation Guidelines

**Table 3: Connection Kits for General Aboveground Piping**

Catalog number	Description	Heating cable allowance <sup>1</sup>
<b>Continued</b>		
 FTC-HST <sup>4</sup>	Low-profile splice/tee; use as needed for pipe branches <b>Standard pkg: 2</b>	3 ft (0.9 m)
 RayClic-E <sup>3</sup>	Replacement end seal <b>Standard pkg: 1</b>	0.3 ft (0.1 m)

<sup>1</sup> For ease of component installation, allow extra heating cable.

<sup>2</sup> Powered splice, powered tee, and cross (tee with three legs) connections are also available.

<sup>3</sup> For grease and fuel lines, install RayClic-LE or end seal off the pipe in junction box.





<sup>4</sup> Not permitted with grease or fuel lines.

<sup>5</sup> Use for circuits supplied with 40 A circuit breaker.

<sup>6</sup> For grease and fuel lines, install tees and splices on pipe mounting bracket (RayClic-SB-04).

## 2 Installation Guidelines

**Table 4: Accessories for General Aboveground Piping**

Catalog number	Description	Heating cable allowance
 ETL	"Electric Traced" label (use 1 label per 10 feet of pipe)	10 labels
 GT-66	Glass cloth adhesive tape for attaching heating cable to pipe at 40°F (4°C) or above. See Table 7.	66 ft
 GS-54	Glass cloth adhesive tape for attaching heating cable to pipe above -40°F (-40°C). See Table 7.	54 ft
 AT-180	Aluminum tape. Required for attaching heating cable to plastic pipe (use 1 foot of tape per foot of heating cable).	180 ft
 RayClic-SB-04	Pipe mounting bracket. Required for mounting the kits off the pipe for exposure temperatures greater than 150°F (65°C) and for grease and fuel line splices and tees.	1 ea

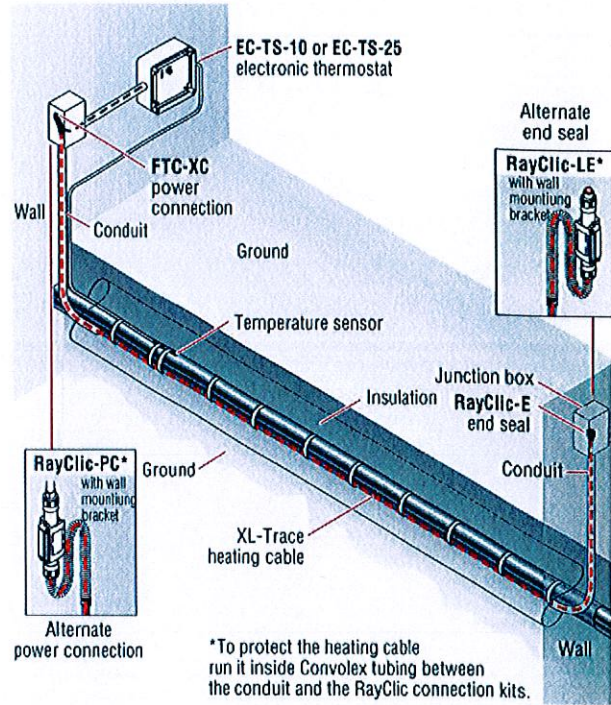

## 2 Installation Guidelines



**Figure 18: Buried pipe XL-Trace System**

## 2 Installation Guidelines

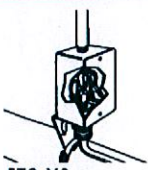
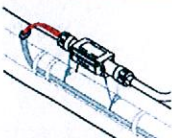
**Table 5. Connection Kits for General Buried Piping**

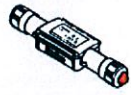
Catalog number	Description	Heating cable allowance*
 FTC-XC	<ul style="list-style-type: none"> <li>• Power connection and end seal</li> <li>• Junction box supplied by customer</li> <li>• Use 1 per circuit</li> </ul> <b>Standard pkg: 1</b>	2 ft (0.6 m)
 RayClic-PC	Power connection and end seal kit <b>Standard pkg: 1</b>	
 RayClic-E	Replacement end seal. <b>Standard pkg: 1</b>	0.3 ft (0.1 m)
 RayClic-LE	Alternate lighted end seal <b>Standard pkg: 1</b>	2 ft (0.6 m)

\* For ease of connection kit installation, allow extra heating cable.

## 2 Installation Guidelines

**Table 6: Accessories for General Buried Piping**

Catalog number	Description	Standard pkg
ETL	"Electric Traced" label (use 1 label per 10 feet of pipe)	10 labels
GT-66	Glass cloth adhesive tape for attaching heating cable to pipe at 40°F (4°C) or above. See Table 7.	66 ft
GS-54	Glass cloth adhesive tape for attaching heating cable to pipe above -40°F (-40°C). See Table 7.	54 ft
AT-180	Aluminum tape. Required for attaching heating cable to plastic pipe (use 1 foot of tape per foot of heating cable).	180 ft
RayClic-SB-02	Wall mounting bracket	1

**Table 7: Quantity of Glass Cloth Adhesive Tape Required (attach at 1-foot intervals)**

Pipe size (in)	<2	3	4	6	8	10
Feet of pipe per GT-66 roll	60	50	40	25	20	15
Feet of pipe per GS-54 roll	49	41	33	20	16	12

# 3

## Thermal Insulation

### 3.1 Insulating the System

Pipes must be insulated with the correct thermal insulation to maintain the desired pipe temperatures. Confirm that the insulation thickness agrees with the system design.

### 3.2 Insulation Installation

- Before insulating the pipe, visually inspect the heating cable and connection kits to ensure they are properly installed and there are no signs of damage. Damaged heating cable or connection kits must be replaced.
- Check that the insulation type and thickness is correct.
- Insulate the pipes immediately after the heating cable is installed and has passed all tests to minimize damage to the heating cable.
- Insulate the pipe at floor and wall penetrations. Failure to do so will cause cold spots in the water system and could lead to damage to the heating cable. If local codes do not allow this, the heating cable should be run through a conduit or channel before the firestop is installed. Use a fire-resistant sealing compound such as Dow Corning Fire Stop, 3M Fire Barrier, or T&B Flame-Safe.
- Do not use staples to seal insulation. Use tape or the adhesive-lined edge of the insulation to ensure that the seam remains sealed. Staples can damage the heating cable.

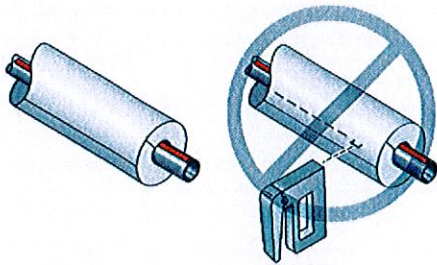

Figure 19: Sealing the insulation seam

- All systems for outdoor, buried, or wet areas must use waterproof fire-resistant thermal insulation.
- Mark the location of splices, tees, and end seals on the outside of the insulation with labels provided in the kits, while installing the insulation. Use large diameter insulation or sheets to cover splices, tees, or service loops.

# 3

## Thermal Insulation

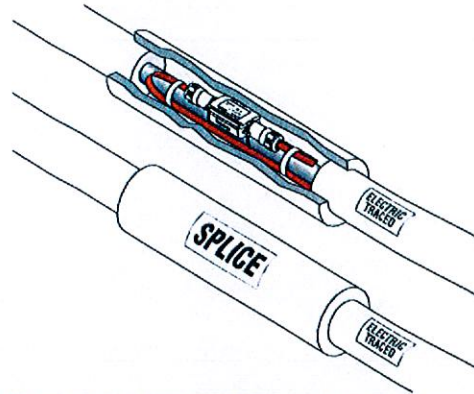

Figure 20: Installing connection kits below insulation

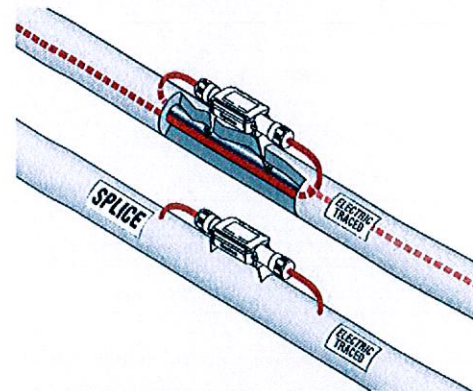

Figure 21: Installing connection kits above insulation

- Make sure that all heat-traced piping, fittings, wall penetrations, and branch piping are insulated. Correctly designed systems require properly installed and dry thermal insulation. Uninsulated or wet sections of pipe can result in cold spots or frozen sections.
- After installing insulation, electrical codes require that you install "Electric Traced" labels along the piping at suitable intervals (10-foot intervals recommended) on alternate sides.

**WARNING:** Use only fire-resistant insulation materials such as fiberglass wrap or flame-retardant foams.

# 4

## Power Supply and Electrical Protection

### 4.1 Voltage Rating

Verify that the supply voltage is either 120 or 208–277 volts as specified by the XL-Trace system design and printed on the jacket of the heating cable.

### 4.2 Circuit Breaker Sizing

Circuit breakers must be sized using the heating cable lengths shown in the Appendix. Do not exceed the maximum circuit length shown for each breaker size. Use circuit breakers that incorporate 30-mA ground-fault circuit protection, or provide equivalent levels of ground-fault protection.

### 4.3 Electrical Loading

The maximum current draw for XL-Trace heating cables is shown in the Appendix. To size the transformer, multiply the total heating cable length (ft) by the appropriate current draw.

### 4.4 Ground-Fault Protection

If the heating cable is improperly installed or physically damaged to the point that water contacts the bus wires, sustained arcing or fire could result. If arcing does occur, the fault current may be too low to trip conventional circuit breakers. Tyco Thermal Controls and national electrical codes require both ground-fault protection of equipment and a grounded metallic covering on all heating cables. Ground-fault protection must be provided by the installer.

**⚠ WARNING:** To minimize the danger of fire from sustained electrical arcing if the heating cable is damaged or improperly installed, and to comply with Tyco Thermal Controls requirements, agency certifications, and national electrical codes, ground-fault equipment protection must be used on each heating cable branch circuit. Arcing may not be stopped by conventional circuit breakers.

**⚠ WARNING:** Disconnect all power before making connections to the heating cable.

# 4

## Power Supply and Electrical Protection

### 4.5 Important Power Supply Safeguards

- Make sure that the heating cable load you are connecting is within the rating of the control system selected. Check the design drawings for the heating cable load.
- The electrical conduit that feeds wiring to the control device must have a low-point drain so condensation will not enter the thermostat enclosure.
- Make sure that the line voltage you are connecting to the control system is correct. For proper wiring, follow the installation instructions enclosed with the control device.

# 5

## Temperature Controls

### 5.1 Ambient-Sensing Control

Ambient-sensing systems energize the circuit when the ambient temperature drops below the set point.

- Mount the device above grade level and out of sunlight.
- Mount the device where it will be exposed to the coldest temperature and the highest wind.

**AMC-1A**  
ambient-sensing  
thermostat

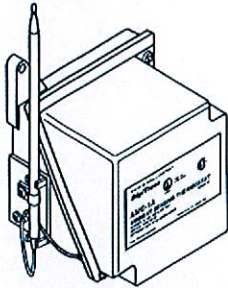

**EC-TS-AMB**  
ambient-sensing  
thermostat

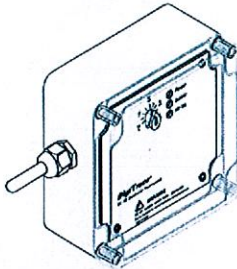

*Figure 22: Ambient-sensing thermostats*

### 5.2 Line-Sensing Control

Line-sensing systems sense the pipe temperature by means of a sensor attached to the pipe and connected to the device.

- Install the sensor on the pipe at 90 degrees from the heating cable so that the heating cable does not thermally interfere with the sensor. Be sure the sensor is firmly attached with aluminum tape to the pipe in order to get good thermal contact between the bulb and the pipe.
- Locate the sensor at least 3 feet (1 meter) from any heat sinks, such as valves, pipe supports, and pumps. Ideally, the sensor should be located at the end of the heating cable circuit.
- Be sure that you set the control to the proper temperature.
- Mount the device on a nearby wall or support, or install a mounting stanchion. Thermostats must be mounted above grade level. In all cases, protect the sensor from physical damage. To prevent damage, mount the device where it will be away from foot and equipment traffic.
- To prevent water entry, seal the insulation where the capillary tube exits the insulation.

# 5

## Temperature Controls

**AMC-1B**  
line-sensing  
thermostat

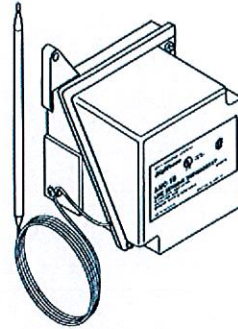

**AMC-F5**  
ambient/line-sensing  
thermostat with a  
fixed setpoint at 40°F

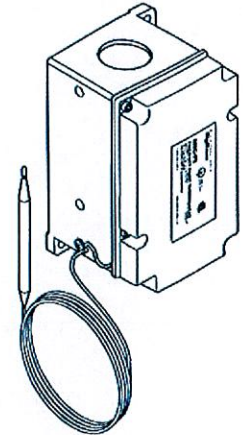

*Figure 23: Mechanical thermostats*

**EC-TS-10/25**  
line-sensing  
electronic thermostat

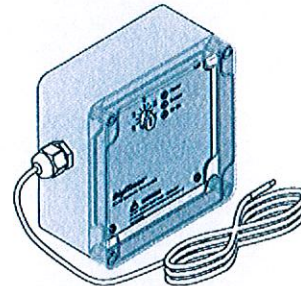

*Figure 24: Electronic thermostat*

# 5 Temperature Controls

DigiTrace 910  
electronic controller

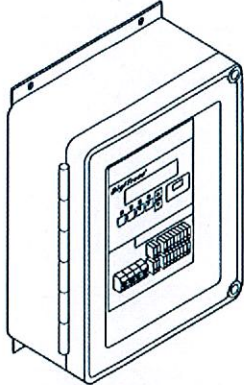

DigiTrace 920  
electronic controller

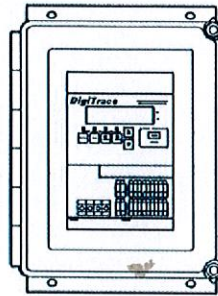

Figure 25: Electronic controllers

# 5 Temperature Controls

## 5.3 Wiring Schematic for Thermostat

The following is a typical wiring schematic for a thermostat.

### Single circuit control

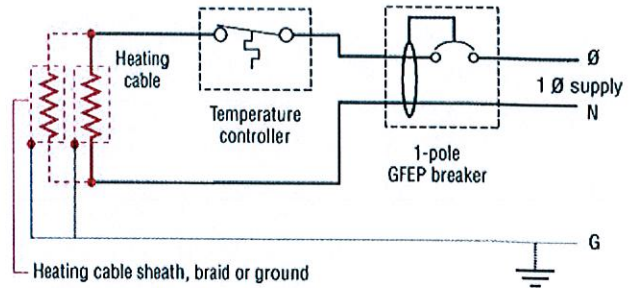

Figure 26: Single circuit control

### Group control

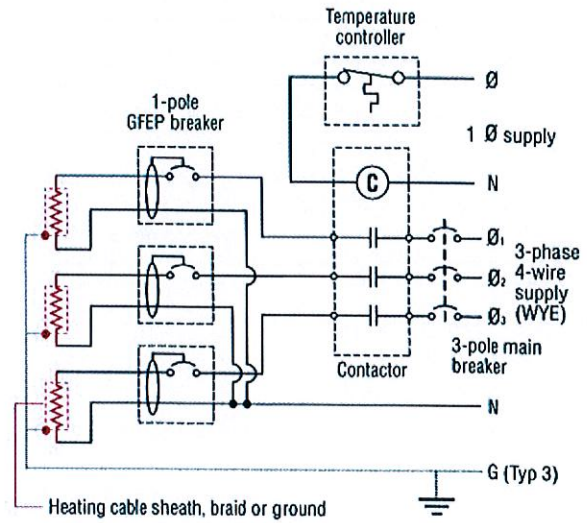

Figure 27: Group circuit control

# 5 Temperature Controls

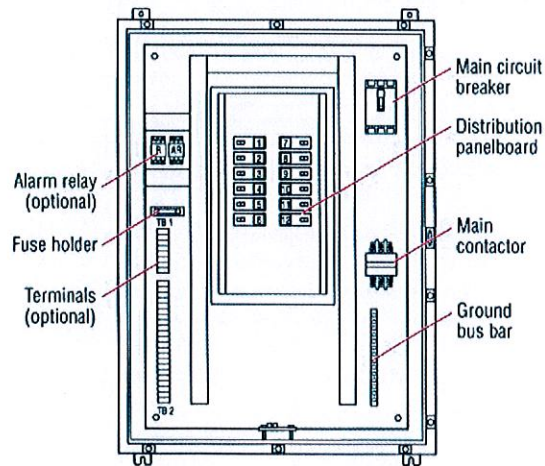
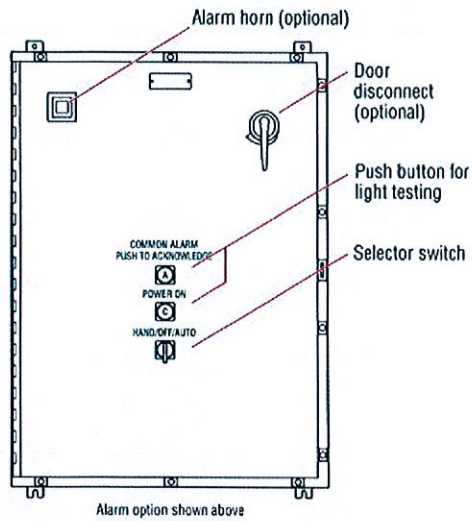

Figure 28: HTPG power distribution panel

# 5 Temperature Controls

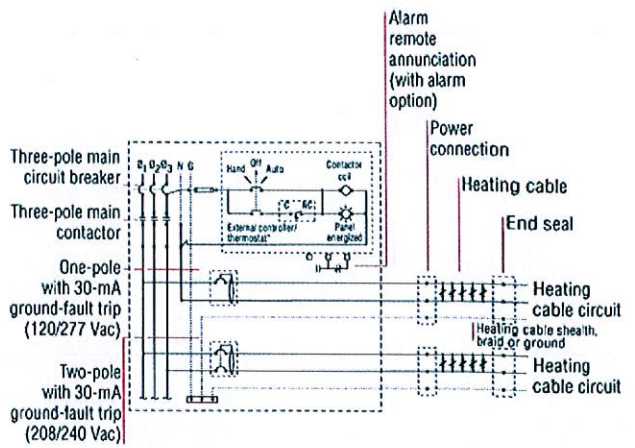

Figure 29: HTPG schematic

# 6

## Commissioning and Preventive Maintenance

Tyco Thermal Controls requires a series of commissioning tests be performed on the XL-Trace system. These tests are also recommended at regular intervals for preventive maintenance. Results must be recorded and maintained for the life of the system, utilizing the "Installation and Inspection Record" (refer to Section 9). Submit this manual with initial commissioning test results to the owner.

### 6.1 Tests

A brief description of each test is found below. Detailed test procedures are found in Section 7.

#### **Visual Inspection**

Visually inspect the pipe, insulation, and connections to the heating cable for physical damage. Check that no moisture is present, electrical connections are tight and grounded, insulation is dry and sealed, and control and monitoring systems are operational and properly set. Damaged heating cable must be replaced.

#### **Insulation Resistance**

Insulation Resistance (IR) testing is used to verify the integrity of the heating cable inner and outer jackets. IR testing is analogous to pressure testing a pipe and detects if a hole exists in the jacket.

#### **Circuit Length Verification (Capacitance Test)**

The installed circuit length is verified through a capacitance measurement of the XL-Trace heating cable. Compare the calculated installed length against the system design. If the calculated length is shorter than the system design, confirm all connections are secure and the grounding braid is continuous.

#### **Power Check**

The power check is used to verify that the system is generating the correct power output. This test can be used in commissioning to confirm that the circuit is functioning correctly. For ongoing maintenance, compare the power output to previous readings.

The heating cable power output per foot is calculated by dividing the total wattage by the total length of a circuit. The current, voltage, operation temperature, and length must be known. Circuit length can be determined from "as built" drawings, meter marks on the heating cable, or with the capacitance test. The watts per foot can be compared to the heating cable output in Figure 32 on page 40 for an indication of heating cable performance.

#### **Ground-Fault Test**

Test all ground-fault breakers per manufacturer's instructions.

# 7

## Test Procedures

### 7.1 System Tests

The following tests must be done after installing the connection kits, but before the thermal insulation is applied to the pipe:

1. Visual inspection
2. Insulation resistance test

After the thermal insulation has been installed on the pipe, the following tests must be performed:

1. Visual inspection
2. Insulation resistance test
3. Circuit length verification (Capacitance test)
4. Power test
5. Temperature test

All test procedures are described in this manual. It is the installer's responsibility to perform these tests or have an electrician perform them. Record the results in the Installation and Inspection Record in Section 10.

#### **Visual Inspection Test**

- Check inside all power, splice, and tee kits for proper installation, overheating, corrosion, moisture, or loose connections.
- Check the electrical connections to ensure that ground and bus wires are insulated over their full length.
- Check for damaged, missing, or wet thermal insulation.
- Check that end seals, splices, and tees are properly labeled on insulation cladding.
- Check the controller for proper setpoint and operation. Refer to its installation and operation manual for details.

#### **Insulation Resistance Test**

##### **Frequency**

Insulation resistance testing is required during the installation process and as part of regularly scheduled maintenance, as follows:

- Before installing the heating cable
- Before installing connection kits
- Before installing the thermal insulation
- After installing the thermal insulation
- Prior to initial start-up (commissioning)
- As part of the regular system inspection
- After any maintenance or repair work

## 7 Test Procedures

### Procedure

Insulation resistance testing (using a megohmmeter) should be conducted at three voltages: 500, 1000, and 2500 Vdc. Potential problems may not be detected if testing is done only at 500 and 1000 volts. First measure the resistance between the heating cable bus wires and the braid (Test A), then measure the insulation resistance between the braid and the metal pipe (Test B). Do not allow test leads to touch junction box, which can cause inaccurate readings.

**Note:** System tests and regular maintenance procedures require that insulation resistance testing be performed. Test directly from the controller or the junction box closest to the power connection.

### Insulation resistance criteria

A clean, dry, properly installed circuit should measure thousands of megohms, regardless of the heating cable length or measuring voltage (500–2500 Vdc).

All insulation resistance values should be greater than 1000 megohms. If the reading is lower, consult Section 8, Troubleshooting Guide.

**Note:** Insulation resistance values for Test A and B for any particular circuit should not vary more than 25 percent as a function of measuring voltage. Greater variances may indicate a problem with your heat-tracing system; confirm proper installation and/or contact Tyco Thermal Controls for assistance.

## 7 Test Procedures

### Test A

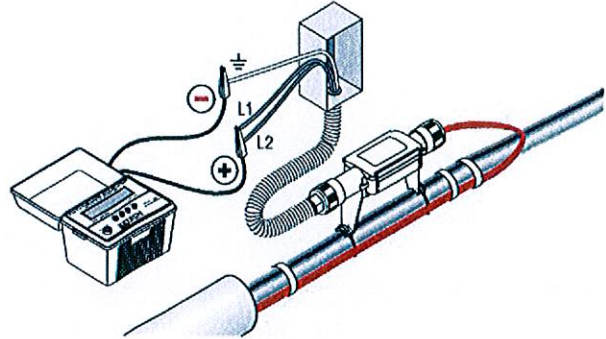

### Test B

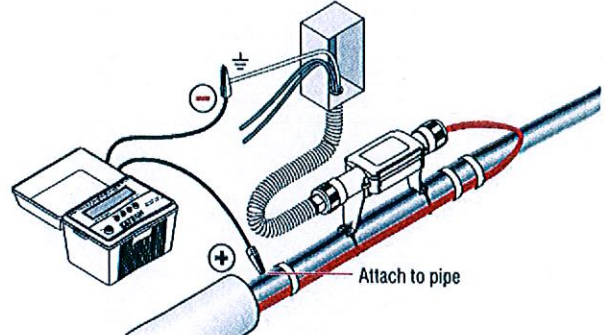

Figure 30: Insulation resistance test

# 7 Test Procedures

## Insulation Resistance test procedure

1. De-energize the circuit.
2. Disconnect the controller if installed.
3. Disconnect bus wires from terminal block.
4. Set test voltage at 0 Vdc.
5. Connect the negative (-) lead to the heating cable metallic braid or RayClic green wire.
6. Connect the positive (+) lead to both heating cable bus wires or RayClic black wires.
7. Turn on the megohmmeter and set the voltage to 500 Vdc; apply the voltage for one minute. Meter needle should stop moving. Rapid deflection indicates a short. Record the insulation resistance value in the Inspection Record.
8. Repeat Steps 4-7 at 1000 and 2500 Vdc.
9. Turn off the megohmmeter.
10. If the megohmmeter does not self-discharge, discharge phase connection to ground with a suitable grounding rod. Disconnect the megohmmeter.
11. Repeat this test between braid and pipe.
12. Reconnect bus wires to terminal block.
13. Reconnect the temperature controller.

## Circuit length verification (capacitance test)

Connect the capacitance meter negative lead to both bus wires and the positive lead to the braid wire. Set the meter to the 200 nF range. Multiply this reading by the capacitance factor for the correct heating cable shown below to determine the total circuit length.

$$\text{Length (ft or m)} = \text{Capacitance (nF)} \times \text{Capacitance factor (ft/nF or m/nF)}$$

**Table 9: Capacitance Factors**

Heating cable	Capacitance factor	
	ft/nF	(m/nF)
5XL and 8XL	5.0	(1.6)
12XL	5.8	(1.8)

Compare the calculated circuit length to the design drawings and circuit breaker sizing tables.

# 7 Test Procedures



**Figure 31: Capacitance test**

## Power Check

The power output of self-regulating heating cable is temperature-sensitive and requires the following special procedure to determine its value:

1. Power the heating cable and allow it to stabilize for 2 hours, then measure current and voltage at the junction box. If a controller is used, refer to details below.
2. Check the pipe temperature under the thermal insulation at several locations.
3. Calculate the power of the heating cable by multiplying the current by the input voltage and dividing by the actual circuit length.

$$\text{Power (w/ft or m)} = \frac{\text{Volts (Vac)} \times \text{Current (Amps)}}{\text{Length (ft or m)}}$$

The power calculated should be similar to the value generated by:

$$\text{Rated Power (w/ft or m)} = \text{Volts (Vac)} \times \text{Rated Current}$$

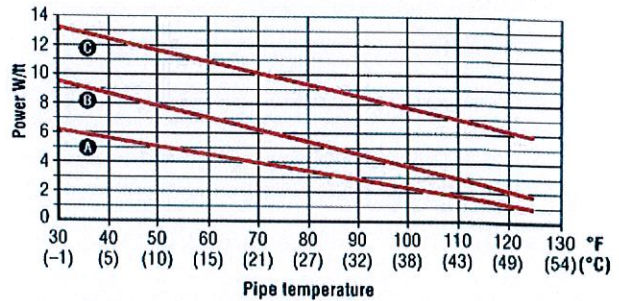

- A** 5XL1-CR and 5XL1-CT (120 V)  
5XL2-CR and 5XL2-CT (208 V)
- B** 8XL1-CR and 8XL1-CT (120 V)  
8XL2-CR and 8XL2-CT (208 V)
- C** 12XL2-CR and 12XL2-CT (208 V)

**Figure 31: Power output**

# 7 Test Procedures

## 7.2 Fault Location Tests

There are three methods used for finding a fault within a section of heating cable.

1. Ratio method
2. Conductance method
3. Capacitance method

### Ratio Method

The ratio method uses resistance measurements taken at each end of the heating cable to approximate the location of a bus wire short. A shorted heating cable could result in a tripped circuit breaker. If the resistance can be read on a standard ohm meter this method can also be used to find a fault from a bus wire to the ground braid. This type of short would trip a GFD and show a failed insulation resistance reading. Measure the bus-to-bus heating cable resistance at each end (measurement A and measurement B) of the suspected section.

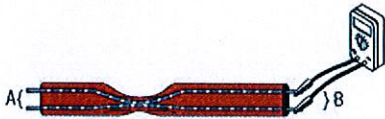

Figure 32: Heating cable resistance measurement test

The approximate location of the fault, expressed as a percentage of the heating cable length from the front end, is:

$$\text{Fault location: } D = \frac{A}{(A + B)} \times 100$$

Example: A = 1.2 ohms  
B = 1.8 ohms

$$\text{Fault location: } D = 1.2 / (1.2 + 1.8) \times 100 = 40\%$$

To locate a low resistance ground fault, measure between bus and braid.

# 7 Test Procedures



Figure 33: Low resistance ground-fault test

The approximate location of the fault, expressed as a percentage of the heating cable length from the front end, is:

$$\text{Fault location: } D = \frac{A}{(A + B)} \times 100$$

Example: A = 1.2 ohms  
B = 1.8 ohms

$$\text{Fault location: } D = 1.2 / (1.2 + 1.8) \times 100 = 40\%$$

The fault is located 40% into the circuit as measured from the front end.

### Conductance Method

The conductance method uses the core resistance of the heating cable to approximate the location of a fault when the heating cable has been severed and the bus wires have not been shorted together. A severed heating cable may result in a cold section of pipe and may not trip the circuit breaker. Measure the bus-to-bus heating cable resistance at each end (measurement A and measurement B) of the suspect section. Since self-regulating heating cables are a parallel resistance, the ratio calculations must be made using the conductance of the heating cable.



Figure 34: Heating cable resistance measurement

The approximate location of the fault, expressed as a percentage of the heating cable length from the front end, is:

$$\text{Fault location: } D = \frac{1/A}{(1/A + 1/B)} \times 100$$

*Example:*     A = 100 ohms  
                  B = 25 ohms

$$\begin{aligned} \text{Fault location: } D &= (1/100) / (1/100 + 1/25) \times 100 \\ &= 20\% \end{aligned}$$

The fault is located 20% from the front end of the circuit.

#### **Capacitance Method**

This method uses capacitance measurement (nF) as described on page 37, to approximate the location of a fault where the heating cable has been severed or a connection kit has not been connected.

Record the capacitance reading from one end of the heating cable. The capacitance reading should be measured between both bus wires twisted together (positive lead) and the braid (negative lead). Multiply the measured capacitance with the heating cable's capacitance factor as listed in the following example:

*Example:*     5XL2-CR = 16.2 nF

Capacitance factor = 5.0 ft/nF

Fault location = 42.2 nF x 5.0 ft/nF = 211 ft (64 m)

The ratio of one capacitance value taken from one end (A) divided by the sum of both A and B (A + B) and then multiplied by 100 yields the distance from the first end, expressed as a percentage of the total heating cable circuit length. See Table 10, page 39, for capacitance factors.

$$\text{Fault location: } C = \frac{A}{(A + B)} \times 100$$

# 8 Troubleshooting Guide

Symptom	Probable Causes	Corrective Action
Circuit breaker trips	Circuit breaker is undersized	Recheck the design for startup temperature and current loads. Do not exceed the maximum circuit length for heating cable used. Replace the circuit breaker if defective or improperly sized.
	Connections and/or splices are shorting out.	Visually inspect the connection kits. Replace if necessary.
	Physical damage to heating cable is causing a direct short.	Check for damage around the valves and any area where there may have been maintenance work. Replace damaged sections of heating cable.
	Bus wires are shorted at the end.	Check the end seal to ensure that bus wires are not shorted. If a dead short is found, the heating cable may have been permanently damaged by excessive current and may need to be replaced.
	Circuit lengths too long.	Separate the circuit into multiple circuits that do not exceed maximum circuit lengths.
	Nick or cut exists in heating cable or power feed wire with moisture present or moisture in connections.	Replace the heating cable, as necessary. Dry out and reseal the connection and splices. Using a megohmmeter, retest insulation resistance.
Low or inconsistent insulation resistance	GFPD is undersized (5 mA used instead of 30 mA) or miswired.	Replace undersized GFPD with 30-mA GFPD. Check the GFPD wiring instructions
	Nicks or cuts in the heating cable.	If heating cable is not yet insulated, visually inspect the entire length for damage, especially at elbows in flanges and around valves. If the system is insulated, remove the connection kits one-by-one to isolate the damaged section.
	Short between the braid and heating cable core or the braid and pipe.	
	Arcing due to damaged heating-cable insulation.	Replace damaged heating-cable sections.
	Moisture present in the connection kits.	If moisture is present, dry out the connections and retest. Be sure all conduit entries are sealed, and that condensate in conduit cannot enter power connection boxes. If heating-cable core or bus wires are exposed to large quantities of water, replace the heating cable. (Drying the heating cable is not sufficient, as the power output of the heating cable can be significantly reduced.)
	Test leads touching the junction box.	Clear the test leads from junction box and restart.

# 9

## Appendix

**Table A1 Circuit Breaker Sizing (Feet)**

Start-up temperature (°F)	CB size (A)	Application 40°F/110°F Maintain*												
		Circuit breaker sizing (ft)												
		5XL1		8XL1		5XL2			8XL1			12XL2		
		120 V	120 V	208 V	240 V	277 V	208 V	240 V	277 V	208 V	240 V	277 V		
-20°F	15	101	76	174	178	183	131	138	146	111	114	117		
	20	134	101	232	237	245	175	184	194	148	151	156		
	30	201	151	349	356	367	262	276	291	223	227	234		
	40	270	201	465	474	478	349	368	388	297	303	312		
0°F	15	115	86	199	203	209	149	157	166	120	122	126		
	20	153	115	265	271	279	199	209	221	160	163	138		
	30	230	172	398	406	419	298	314	331	239	244	252		
	40	270	210	470	490	530	<i>370/399</i>	<i>390/420</i>	<i>420/443</i>	319	326	336		
20°F	15	134	100	232	237	244	173	182	192	126	129	133		
	20	178	133	309	315	325	231	243	257	169	172	177		
	30	270	200	464	473	488	346	365	385	253	258	266		
	40	270	210	470	490	530	<i>370/462</i>	<i>390/486</i>	<i>420/513</i>	<i>340/349</i>	344	355		
40°F	15	160	119	278	283	292	206	217	229	142	145	150		
	20	214	159	370	378	390	275	290	306	190	194	200		
	30	270	210	470	490	530	<i>370/416</i>	<i>390/438</i>	<i>420/462</i>	285	291	300		
	40	270	210	470	490	530	<i>370/554</i>	<i>390/584</i>	<i>420/616</i>	<i>349/398</i>	<i>360/406</i>	<i>380/419</i>		
50°F (buried)	15	-	-	-	-	-	<i>228</i>	<i>240</i>	<i>254</i>	<i>152</i>	<i>155</i>	<i>160</i>		
	20	-	-	-	-	-	<i>304</i>	<i>320</i>	<i>338</i>	<i>203</i>	<i>207</i>	<i>213</i>		
	30	-	-	-	-	-	<i>457</i>	<i>481</i>	<i>507</i>	<i>304</i>	<i>310</i>	<i>320</i>		
	40	-	-	-	-	-	<i>609</i>	<i>641</i>	<i>676</i>	<i>405</i>	<i>414</i>	<i>427</i>		
65°F (indoors grease)	15	-	-	-	-	-	<i>272</i>	<i>286</i>	<i>302</i>	<i>169</i>	<i>172</i>	<i>178</i>		
	20	-	-	-	-	-	<i>362</i>	<i>381</i>	<i>402</i>	<i>225</i>	<i>230</i>	<i>237</i>		
	30	-	-	-	-	-	<i>543</i>	<i>572</i>	<i>603</i>	<i>338</i>	<i>345</i>	<i>356</i>		
	40	-	-	-	-	-	<i>610</i>	<i>660</i>	<i>720</i>	<i>430</i>	<i>460</i>	<i>490</i>		

\* When circuit breaker sizing is listed in:  
 • black type, the value is for applications with a 40°F maintain  
 • red italic type, the value is for applications with a 110°F maintain

# 9

## Appendix

**Table A2 Circuit Breaker Sizing (Meters)**

Minimum start-up temperature (°C)	CB size (A)	Application 4°C/43°C Maintain*											
		Circuit breaker sizing (m)											
		5XL1 120 V	8XL1 120 V	5XL2 208 V 240 V 277 V			8XL1 208 V 240 V 277 V	12XL2 208 V 240 V 277 V					
-29°C	15	31	23	53	54	56		40	42	44	34	35	36
	20	41	101	71	72	75		53	56	59	45	46	48
	30	61	151	106	108	112		80	84	89	68	69	71
	40	82	201	142	145	149		106	112	118	90	92	95
-18°C	15	35	86	61	62	64		45	48	51	36	37	38
	20	47	115	81	83	85		61	64	67	49	50	51
	30	70	172	121	124	128		91	96	101	73	74	77
	40	82	210	143	149	162		113/122	119/128	128/135	97	99	102
-7°C	15	41	100	71	72	74		53	56	59	39	39	41
	20	54	133	94	96	99		70	74	78	51	52	54
	30	82	200	141	144	149		106	111	117	77	79	81
	40	82	210	143	149	162		113/141	119/148	128/156	104/106	105	108
40°C	15	49	119	85	86	89		63	66	70	43	44	46
	20	65	159	113	115	119		84	88	93	58	59	61
	30	82	210	143	149	162		113/127	119/134	128/141	87	89	91
	40	82	210	143	149	162		113/169	119/178	128/188	104/121	110/124	116/128
10°C (buried grease)	15	-	-	-	-	-		70	73	77	46	47	49
	20	-	-	-	-	-		93	98	103	62	63	65
	30	-	-	-	-	-		139	147	155	93	95	98
	40	-	-	-	-	-		186	195	206	124	126	130
18°C (indoors grease)	15	-	-	-	-	-		83	87	92	52	53	54
	20	-	-	-	-	-		110	116	123	69	70	72
	30	-	-	-	-	-		166	174	184	103	105	108
	40	-	-	-	-	-		186	201	220	131	140	149

\* When circuit breaker sizing is listed in:  
 • black type, the value is for applications with a 4°C maintain  
 • red italic type, the value is for applications with a 43°C maintain

# 9 Appendix

**Table A3 Transformer Sizing (Amperes/foot)**

Minimum start-up temperature (°F)	5XL1	8XL1	5XL2			8XL1			12XL2		
	120 V	120 V	208 V	240 V	277 V	208 V	240 V	277 V	208 V	240 V	277 V
-20	0.119	0.159	0.069	0.067	0.065	0.092	0.087	0.082	0.108	0.106	0.102
0	0.105	0.139	0.060	0.059	0.057	0.080	0.076	0.072	0.100	0.098	0.095
20	0.090	0.120	0.052	0.051	0.049	0.069	0.066	0.062	0.095	0.093	0.090
40	0.075	0.101	0.043	0.042	0.041	0.058	0.055	0.052	0.084	0.083	0.080
50	-	-	-	-	-	0.053	0.050	0.047	0.079	0.077	0.075
65	-	-	-	-	-	0.044	0.042	0.040	0.072	0.070	0.067

**Table A4 Transformer Sizing (Amperes/meter)**

Minimum start-up temperature (°C)	5XL1	8XL1	5XL2			8XL1			12XL2		
	120 V	120 V	208 V	240 V	277 V	208 V	240 V	277 V	208 V	240 V	277 V
-20	0.391	0.521	0.226	0.221	0.215	0.301	0.286	0.270	0.354	0.347	0.336
-18	0.343	0.457	0.198	0.194	0.188	0.264	0.251	0.238	0.329	0.322	0.312
-7	0.294	0.394	0.170	0.166	0.161	0.227	0.216	0.205	0.311	0.305	0.296
4	0.246	0.331	0.142	0.139	0.135	0.191	0.181	0.172	0.276	0.271	0.263
10	-	-	-	-	-	0.172	0.164	0.155	0.259	0.254	0.246
18	-	-	-	-	-	0.145	0.138	0.130	0.233	0.228	0.221

# 10 Installation and Inspection Record

## Installation and Inspection Record

Facility				
Test Date:				
Circuit number:				
Heating cable type:				
Controllers:				
Temperature setting:				
Circuit length:				
<b>Commission</b>				
<b>Inspection date:</b>				
<b>Visual Inspection</b>				
Confirm 30-mA ground-fault device (proper rating/function)				
Visual inspection inside connection boxes for overheating, corrosion, moisture, and other problems.				
Proper electrical connection, ground, and bus wires insulated over full length				
Damaged or missing thermal insulation; damaged, missing, cracked lagging or weatherproofing.				
Covered end seals, splices, and tees properly labeled on insulation.				
Check controllers for moisture, corrosion, setpoint, switch operation.				
<b>Insulation resistance test</b>	<b>M-Ohms</b>			
Bus to braid (Test A)	500 Vdc			
	1000 Vdc			
	2500 Vdc			
Braid to pipe (Test B)	500 Vdc			
	1000 Vdc			
	2500 Vdc			
<b>Circuit length verification</b>				
Capacitance test: Circuit length (ft) = Capacitance (nF) x Capacitance factor (x 3.28 = m)				
<b>Power check</b>				
Circuit voltage				
Panel	(Vac)			
Circuit amps after 2 hours	(Amps)			
Pipe temperature	(°F) (°C)			
Power = (volts x amps after 2 hrs) / circuit length (watts/ft) (watts/m)				

## Section 9: Operation & Maintenance for Steam Conduit

**Annual:** Remove the drain plugs to check for the presence of water in the air space yearly. When removing the drain plug, be alert for a possible steam flash. If water is found follow the repair procedure outlined below. The drain plugs must be replaced after the inspection to insure water does not inadvertently enter the air space from a flooded manhole or mechanical room.

**CAUTION:** Extreme caution must be exercised when entering steam manholes and opening vents and drains.

Also do an air test of the conduit yearly. Using an air compressor, pressurize the air space to 15 psig and hold for one (1) hour. If the pressure can not be maintained, see the repair procedure below. Warranty will void if this is not done and logged year to year.

**Repair:** If a leak in the casing is found, it should be repaired, tested, coated, and backfilled as it was originally installed.

If a leak in the carrier pipe is found, at least a 2' section of pipe should be removed and replaced. The carrier pipe should then be hydrostatically tested at 1½ times it's operating pressure, not to exceed 500 psig. Re-insulate the carrier pipe as specified. Repair the inner conduit casing using a split sleeve, similar to the connector band used in assembling the field joints. Air test the inner conduit casing, then insulate as specified. Cover with a polyethylene sleeve and seal with a wrap around shrink sleeve.

**Insulation:** If insulation within the conduit becomes wet, then force ventilate the air space in the system at a rate of not less than 3 cubic feet per minute, and apply heat through the internal piping. Introduce the air through the system's high point vent, and force out the low point drain. Caution personnel regarding the possibility of a steam flash out of the low point drain while air is being forced through the system. Place a cool mirror at the exhaust point for a short time at appropriate intervals and position to indicate maximum fogging due to moisture. Continue ventilation until the mirror exhibits no visible fogging.

**System Shutdown:** If the system is shut down for any length of time, seal the system vents by plugging the goose neck or removing it and installing a plug. Purge with dry nitrogen before sealing system. The vents must be opened and the goose neck replaced before the system is turned on again. This will prevent moisture entry during shutdown.

**Manholes:** Automatic sump pumps, if any, should be thoroughly inspected for proper operation annually. Steam traps, if any, should be routinely inspected and/or replaced, based upon the recommendations of the manufacturer. All flanges should be checked for leakage and tightened if necessary. Any evidence of groundwater leakage should be investigated and repaired. Gland seals, end seals, and the inside wall of prefabricated steel manholes should be routinely inspected for leaks and/or corrosion. Sand and repaint any corrosion to match the existing coating. Check valves routinely for leaks and repack when necessary. Insulation and jacketing of internal piping and equipment should routinely be checked and replaced when necessary. Warranty will void if manholes flood over Rovanco's piping systems.

*If you have any questions about anything in this instruction manual, or have any difficulty in completing the work please feel free to contact ROVANCO's Customer Service Department at our main office in Joliet, Illinois (815) 741-6700.*

*Thank you once again for showing your confidence in ROVANCO by purchasing our Hi-Temp Insul-8 products. We want you to know that we have a full line of pre-insulated and pre-fabricated piping systems for almost any temperature, pressure, or site condition.*

*If you are not familiar with our complete product line and you would like to know more about our product or would like to have our local Manufacturer's Representative call on you, call ROVANCO at (815) 741-6700, at rovanco.com, or email us at marketing@rovanco.com*

## Section 10: Parameters For Properly Installing & Operating Systems

Rovanco's pre-insulated and pre-fabricated products are carefully engineered to function as intended. If these products are properly installed, fully-tested, maintained and operated within the parameters for which they were designed, these systems should provide the user with years of trouble-free, efficient operation.

Refer to Rovanco's Installation Instruction(s) and the associated documentation from Rovanco's Engineering Department for important information and instructions that will carefully detail installation, testing, operating, and maintenance procedures. If needed, you are always welcome to contact Rovanco for assistance.

Failure to comply with the procedures as outlined in the Installation Instructions and Engineering support documentation could result in product damage, reduced product service life, costly repairs due to product failure, hazardous conditions which could result in injury to people, property and/or equipment. In addition, it will void Rovanco's warranty.

**If any Rovanco product does not perform as it is intended to, please inform Rovanco immediately.**

Some problems and their potential causes are listed below. Although this list is not all-inclusive, you may be able to find additional information in Rovanco's Installation Instruction(s) and/or the Engineering Department documentation.

### General Piping System Care:

- Wet insulation does not perform as intended and causes the premature failure of the system. Therefore, it is important the system's insulation is kept dry at all times. This includes during storage, installation and when system is operating.
- Our systems have been engineered to operate within a specific temperature & pressure range and under appropriate environmental conditions. Therefore, do not install or put our systems into service if these parameters are not within the product's specifications.
- If you find it is necessary to alter a Rovanco piping system, review the planned alterations with Rovanco or a qualified piping system designer before making any changes.
- Maintenance plays an important role in assuring you get the full service-life out of the system. Rovanco systems are designed to provide years of trouble-free operation, but changing conditions can affect that. So, systems should be inspected regularly to verify they are in good operating condition and functioning as intended. If repairs are required, make them promptly.

### Pre-Insulated Foam Systems:

- Piping systems must be kept dry. Moisture of any amount can corrode carrier pipe and prematurely breakdown insulation. This will shorten piping system service-life and/or prevent it from operating properly. Keep all piping system dry during storage, installation and when it is operating.
- Assure field joints are completed correctly. This includes the proper field insulating and enclosing the outer jacket in the joint area. Improper completion of field joints could result in water ingress effecting carrier pipe and/or insulation.
- Damage to jacketing must be repaired immediately. Failure to do so could allow moisture to reach the insulations and/or carrier pipe.
- When installing piping systems designed for underground use that require external expansion pads, you must assure these expansion pads are properly installed according to specifications. Proper installation will allow for associated thermal expansion. Improperly installed expansion pads will put unwanted stress on a piping system that could damage it.

## **Conduit & Containment Systems:**

- Moisture negatively affects a systems functionality and shortens its service-life. Moisture will corrode carrier, conduit & containment piping, leak detection or pull cables and it will degrade insulation. It is important that the air space in these systems is kept dry. If any type of moisture is detected, it must be dried immediately so system is returned to a dry state during installation and operation.
- A combination of moisture in the air space and high operating temperatures will accelerate the destruction of piping, its coating and any insulation. This can result in costly repairs, system damage and possibly system failure. Therefore, do not ever operate these systems under the negative conditions of moisture presence and high temperatures.
- Gland seals provide a seal against a service pipe while still allowing that service pipe to have axial movement. Therefore, it is important all gland seals are adjusted properly to these conditions are met and there is no binding of the service pipe.
- End seal vents and drain piping play an important role in keeping the air space dry. They allow the annular air space to vent and drain as well as prevent moisture ingress. So it is important end seal vents and drain piping is installed properly. This will allow them to function as intended.
- One important detail that will help keep the air space dry and drainable is to assure the piping system is installed with the proper slope so any moisture can drain as intended.

## **Systems Intended For Underground Installation:**

- Plan for adverse weather conditions prior to installation. If trenches gather water, they must be drained prior to the installation of the piping.
- Inspect all steel piping that will be buried prior to backfilling using a Holiday tester. Any holidays or damage to coating must be repaired in accordance with Rovanco's installation instructions prior to backfilling. Failure to repair voids or damage to coating will promote premature corrosion and effect system performance and length of service.
- Prior to backfilling, all carrier pipe, conduit and containment piping must be tested. If piping system integrity is not tested prior to backfilling, it will result in costly excavating and will not be Rovanco's responsibility.
- Cathodic protection system must be installed with thin-coated steel conduit or containment that will be direct buried. The cathodic protection will prevent the premature corrosion of thin-coated steel piping system.
- Line trench accordingly before piping installation. Backfill and compact post-installation in accordance with Rovanco's installation instructions. If these procedures are performed properly, it will help prevent damage to the system when the ground settles.
- Manholes must be kept dry at all times. Installing sump pumps, keeping end seals above water levels and not installing manholes in low points will help prevent water from draining into them.