

Rovanco® Piping Systems

20535 S.E. Frontage Road
Joliet, IL 60431
(815) 741-6700

INS-LDC

Leak Detection Cable for Containment Pipe Only Installation Instructions

Revised 09/05/23

If the piping system that you are installing has leak detection, follow these instructions carefully before starting the installation. Many precautions must be taken to insure proper installation. Improper installation can be very costly and time consuming. It is very important to keep the inside of the containment piping dry and free to contaminants throughout the installation. If you have any questions please call Customer Service at (815) 741-6700.

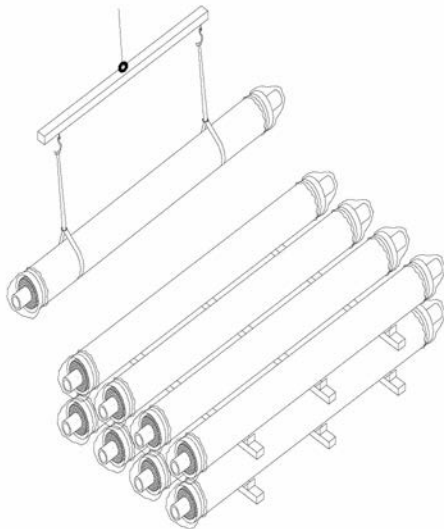

STORAGE

The pipe and fittings must be stored on dunnage and kept sheltered from rain. Accessories should also be stored and sheltered from rain. Inspect the bags on the end of each pipe to make sure they have not been damaged during shipment. If there is any damage, seal the end with plastic.

Table of Contents

Page

Section 1	Pull Rope for Leak Detection Cable Installation Instructions	3-5
Section 2	Operation & Maintenance Instructions for Steam Conduit	6
Section 3	Parameters for Properly Installing & Operating Systems	7-8

Testing

All carrier pipe must either be air or hydro tested per specifications prior to insulating and pouring thrust blocks around anchors or backfilling the system. Failure to comply with testing procedures will void warranty. Plastic carrier pipe must be hydro tested only, do not air test.

ROVANCO's products and processes are covered under various US patents, including, but not limited to 4,084,842 - 4,484,386 - 4,221,405 - 3,793,411.

Insul-8 and ROVANCO are Federally Registered trademarks of ROVANCO Piping Systems, Inc.

For additional Leak Detection Installation Instructions, contact Rovanco for INS-RAT

Section 1: Pull Rope for Leak Detection Cable Installation Instructions

Fig. 1.1



Fig. 1.2

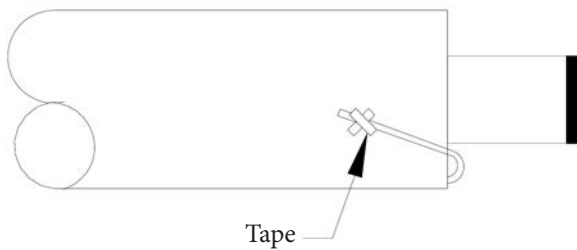

Fig. 1.3

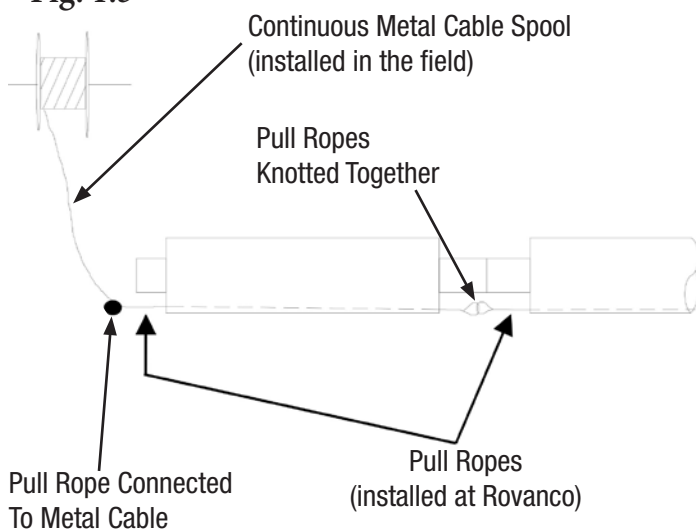
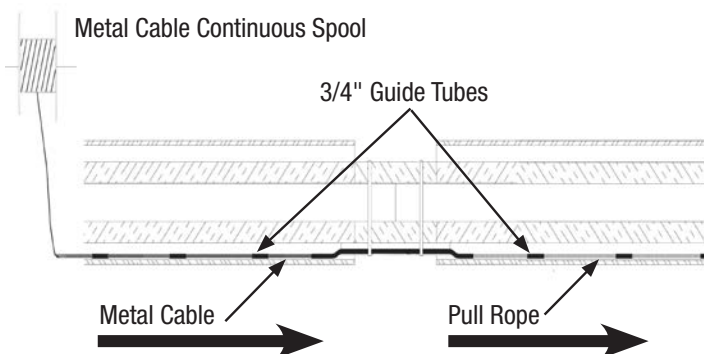

Fig. 1.4



Note: During any welding processes do NOT use anti-splatter or any type of lubricant IF your system has leak detection. These materials can cause the leak detection to fail.

Preparation – Before Carrier Pipe Welding

1. Each piece of pipe will be supplied with its own pull rope which has been threaded through a series of semi-flexible 3/4" guide tubes that are positioned at intervals inside the length of pipe. The end of the rope is taped to the carrier pipe at both ends. Do not cut the rope loose until the pipe is in the trench and carrier pipe is ready to be joined.

See Figure 1.1

2. Once the pipe is in the trench and carrier is ready to be joined, carefully cut the tape loose and tape the rope back to the jacket so the rope does not get burned when welding and free of glue, epoxy or resin on PVC or fiberglass systems. **See Figure 1.2**

Proceed with joining the carrier pipe. If the joints are to be exposed overnight or for any period of time, use a white tarp or white visqueen to seal the joints.

Preparation – Before Pulling Metal Cable

3. Once all of the carrier pipe joints are welded and tested, you are ready to connect the pull rope from one pipe length to the pull rope of another. Use a loop or slip knot to connect pull ropes. Use electrical tape to flatten down any loose ends and to secure knot so the two rope do not pull apart during pulling process.
4. Set up the spool of metal cable at one end of the system. Then connect the pull rope end to the cable.

See Figure 1.3

The pipe has centering supports with sections of 3/4" conduit guides for the pull ropes and metal cable to run through. Make sure the pull rope/metal cable connection does not get bound up in these guides, **it is strongly recommended to tie the pull rope end to the continuous metal cable using the procedure shown on page 4.** This method will minimize issues during the pulling process.

5. Once rope and cable are connected at one end, pull the opposite, loose end of the rope so the continuous metal cable is pulled the full length of the pipe section and follows the rope through the 3/4" guide tubes. The continuous metal cable needs to be pulled enough to move the rope out of the joint area prior to welding conduit connector bands. **See Figure 1.4**

TT-Aircraft to TT-PR (Pull Rope) Connection Installation Instructions



Wrap approximately 4 inch end of TT-PR with electrical tape forming a point.



Open up hollow braid approximately 12-14 inches from end to insert taped point into the braiding.



Insert entire taped portion of pull rope end into the braiding.



Loop should look like this.



Use Scotch 33+ electrical tape to wrap section where point was inserted into the braid tightly.

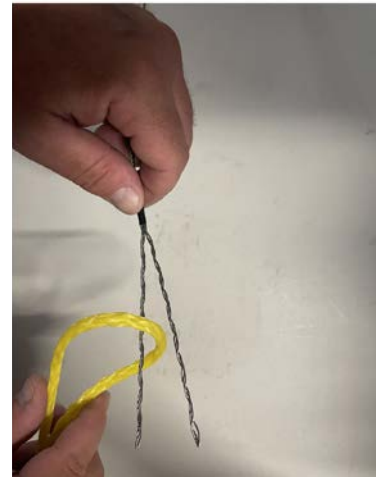

Uncoil steel aircraft cable into 2 halves approximately 5 inches long and tape at base of this "V" with electrical tape ("V" hidden under top thumb in this photo). Insert braided loop between these sections.

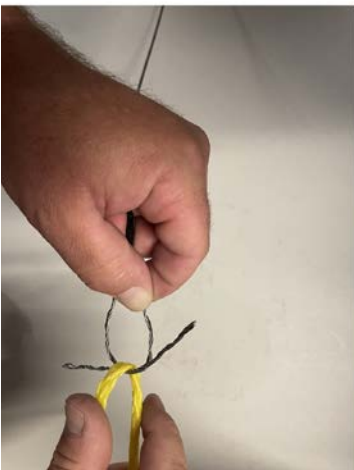

Loop steel cable around braided cable from each end in opposite directions twisting steel cable end around itself at least 2 times on each side forming a steel cable loop.



Use pliers to pinch steel cable loop.



Stretch both cables and apply electrical tape from one end to the other, then back to starting point. Note: While wrapping electrical tape, pull to make this tight in order to lower the profile of the section for ease of pulling.

NOTE: Steel aircraft cable to be pulled prior to welding 10 gauge. After 10 gauge has been welded and tested per spec, then the leak detection cable can be pulled.

Fig. 1.5

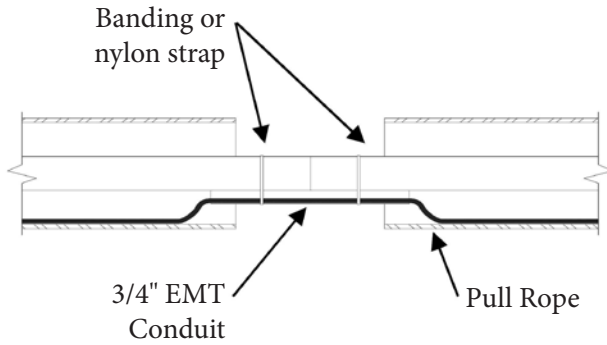

6. The center 15" of the guide tube is flexible. Use banding or nylon strap to position that portion of the guide tube system away from the edges of where the connector bands will be welded. **See Figure 1.5**

Make sure the cable is not stuck or bound up by pulling it in each direction at least 20-ft. If the cable does not move freely check all guide tubes to see if you can find where the issue is and make necessary adjustments.

NOTE: Do not pull the actual Leak Detection Cable through until the connector band welding is complete and system has been tested. This is to prevent the possibility of damage or contamination to the leak detection cable.
Preparation – Before Pulling Leak Detection Cable

Fig. 1.6

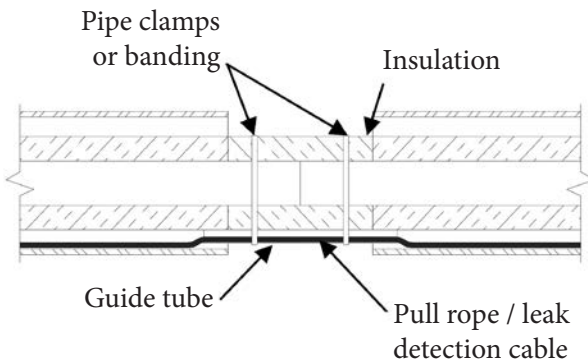

7. After the continuous cable is pulled and properly positioned in the joint area, begin the conduit connector bands process. **See Figure 1.6**

NOTE: Refer to the pipe installation instruction section for details associated with that procedure. Any other procedures such as fitting, end seal and outer jacket insulating & coupling are covered in their respective sections in the instructions.

8. After conduit connector bands are fully welded and tested, move cable back & forth again to be sure it is still free. Then connect end of metal cable to leak detection cable. You can utilize the same connection process suggested for connecting pull rope to metal cable on **page 4**.

Pull metal cable, now attached to leak detection cable, through the system. This is to be done before insulating and making the outer jacketing joints.

It will depend on the pipe run as to whether you pull leak detection the entire length of a straight pipe run or to a pull port. See specs for details.

It is extremely important to pull the Leak Detection cable and test it prior to backfilling! See Figure 1.7

Fig. 1.7

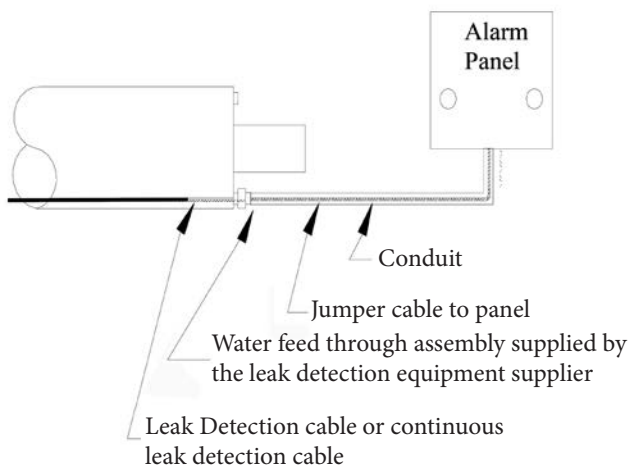

Section 2: Operation & Maintenance for Steam Conduit

Annual: Remove the drain plugs to check for the presence of water in the air space yearly. When removing the drain plug, be alert for a possible steam flash. If water is found follow the repair procedure outlined below. The drain plugs must be replaced after the inspection to insure water does not inadvertently enter the air space from a flooded manhole or mechanical room.

CAUTION: Extreme caution must be exercised when entering steam manholes and opening vents and drains.

Also do an air test of the conduit yearly. Using an air compressor, pressurize the air space to 15 psig and hold for one (1) hour. If the pressure can not be maintained, see the repair procedure below. Warranty will void if this is not done and logged year to year.

Repair: If a leak in the casing is found, it should be repaired, tested, coated, and backfilled as it was originally installed.

If a leak in the carrier pipe is found, at least a 2' section of pipe should be removed and replaced. The carrier pipe should then be hydrostatically tested at 1½ times it's operating pressure, not to exceed 500 psig. Re-insulate the carrier pipe as specified. Repair the inner conduit casing using a split sleeve, similar to the connector band used in assembling the field joints. Air test the inner conduit casing, then insulate as specified. Cover with a polyethylene sleeve and seal with a wrap around shrink sleeve.

Insulation: If insulation within the conduit becomes wet, then force ventilate the air space in the system at a rate of not less than 3 cubic feet per minute, and apply heat through the internal piping. Introduce the air through the system's high point vent, and force out the low point drain. Caution personnel regarding the possibility of a steam flash out of the low point drain while air is being forced through the system. Place a cool mirror at the exhaust point for a short time at appropriate intervals and position to indicate maximum fogging due to moisture. Continue ventilation until the mirror exhibits no visible fogging.

System Shutdown: If the system is shut down for any length of time, seal the system vents by plugging the goose neck or removing it and installing a plug. Purge with dry nitrogen before sealing system. The vents must be opened and the goose neck replaced before the system is turned on again. This will prevent moisture entry during shutdown.

Manholes: Automatic sump pumps, if any, should be thoroughly inspected for proper operation annually. Steam traps, if any, should be routinely inspected and/or replaced, based upon the recommendations of the manufacturer. All flanges should be checked for leakage and tightened if necessary. Any evidence of groundwater leakage should be investigated and repaired. Gland seals, end seals, and the inside wall of prefabricated steel manholes should be routinely inspected for leaks and/or corrosion. Sand and repaint any corrosion to match the existing coating. Check valves routinely for leaks and repack when necessary. Insulation and jacketing of internal piping and equipment should routinely be checked and replaced when necessary. Warranty will void if manholes flood over Rovanco's piping systems.

If you have any questions about anything in this instruction manual, or have any difficulty in completing the work please feel free to contact ROVANCO's Customer Service Department at our main office in Joliet, Illinois (815) 741-6700.

Thank you once again for showing your confidence in ROVANCO by purchasing our Hi-Temp Insul-8 products. We want you to know that we have a full line of pre-insulated and pre-fabricated piping systems for almost any temperature, pressure, or site condition.

If you are not familiar with our complete product line and you would like to know more about our product or would like to have our local Manufacturer's Representative call on you, call ROVANCO at (815) 741-6700, at rovanco.com, or email us at marketing@rovanco.com

Section 3: Parameters For Properly Installing & Operating Systems

Rovanco's pre-insulated and pre-fabricated products are carefully engineered to function as intended. If these products are properly installed, fully-tested, maintained and operated within the parameters for which they were designed, these systems should provide the user with years of trouble-free, efficient operation.

Refer to Rovanco's Installation Instruction(s) and the associated documentation from Rovanco's Engineering Department for important information and instructions that will carefully detail installation, testing, operating, and maintenance procedures. If needed, you are always welcome to contact Rovanco for assistance.

Failure to comply with the procedures as outlined in the Installation Instructions and Engineering support documentation could result in product damage, reduced product service life, costly repairs due to product failure, hazardous conditions which could result in injury to people, property and/or equipment. In addition, it will void Rovanco's warranty.

If any Rovanco product does not perform as it is intended to, please inform Rovanco immediately.

Some problems and their potential causes are listed below. Although this list is not all-inclusive, you may be able to find additional information in Rovanco's Installation Instruction(s) and/or the Engineering Department documentation.

General Piping System Care:

- Wet insulation does not perform as intended and causes the premature failure of the system. Therefore, it is important the system's insulation is kept dry at all times. This includes during storage, installation and when system is operating.
- Our systems have been engineered to operate within a specific temperature & pressure range and under appropriate environmental conditions. Therefore, do not install or put our systems into service if these parameters are not within the product's specifications.
- If you find it is necessary to alter a Rovanco piping system, review the planned alterations with Rovanco or a qualified piping system designer before making any changes.
- Maintenance plays an important role in assuring you get the full service-life out of the system. Rovanco systems are designed to provide years of trouble-free operation, but changing conditions can affect that. So, systems should be inspected regularly to verify they are in good operating condition and functioning as intended. If repairs are required, make them promptly.

Pre-Insulated Foam Systems:

- Piping systems must be kept dry. Moisture of any amount can corrode carrier pipe and prematurely breakdown insulation. This will shorten piping system service-life and/or prevent it from operating properly. Keep all piping system dry during storage, installation and when it is operating.
- Assure field joints are completed correctly. This includes the proper field insulating and enclosing the outer jacket in the joint area. Improper completion of field joints could result in water ingress effecting carrier pipe and/or insulation.
- Damage to jacketing must be repaired immediately. Failure to do so could allow moisture to reach the insulations and/or carrier pipe.
- When installing piping systems designed for underground use that require external expansion pads, you must assure these expansion pads are properly installed according to specifications. Proper installation will allow for associated thermal expansion. Improperly installed expansion pads will put unwanted stress on a piping system that could damage it.

Conduit & Containment Systems:

- Moisture negatively affects a systems functionality and shortens its service-life. Moisture will corrode carrier, conduit & containment piping, leak detection or pull cables and it will degrade insulation. It is important that the air space in these systems is kept dry. If any type of moisture is detected, it must be dried immediately so system is returned to a dry state during installation and operation.
- A combination of moisture in the air space and high operating temperatures will accelerate the destruction of piping, its coating and any insulation. This can result in costly repairs, system damage and possibly system failure. Therefore, do not ever operate these systems under the negative conditions of moisture presence and high temperatures.
- Gland seals provide a seal against a service pipe while still allowing that service pipe to have axial movement. Therefore, it is important all gland seals are adjusted properly to these conditions are met and there is no binding of the service pipe.
- End seal vents and drain piping play an important role in keeping the air space dry. They allow the annular air space to vent and drain as well as prevent moisture ingress. So it is important end seal vents and drain piping is installed properly. This will allow them to function as intended.
- One important detail that will help keep the air space dry and drainable is to assure the piping system is installed with the proper slope so any moisture can drain as intended.

Systems Intended For Underground Installation:

- Plan for adverse weather conditions prior to installation. If trenches gather water, they must be drained prior to the installation of the piping.
- Inspect all steel piping that will be buried prior to backfilling using a Holiday tester. Any holidays or damage to coating must be repaired in accordance with Rovanco's installation instructions prior to backfilling. Failure to repair voids or damage to coating will promote premature corrosion and effect system performance and length of service.
- Prior to backfilling, all carrier pipe, conduit and containment piping must be tested. If piping system integrity is not tested prior to backfilling, it will result in costly excavating and will not be Rovanco's responsibility.
- Cathodic protection system must be installed with thin-coated steel conduit or containment that will be direct buried. The cathodic protection will prevent the premature corrosion of thin-coated steel piping system.
- Line trench accordingly before piping installation. Backfill and compact post-installation in accordance with Rovanco's installation instructions. If these procedures are performed properly, it will help prevent damage to the system when the ground settles.
- Manholes must be kept dry at all times. Installing sump pumps, keeping end seals above water levels and not installing manholes in low points will help prevent water from draining into them.