

# Rovanco FRP Pipe System

For Temperatures to 210°F Below Ground

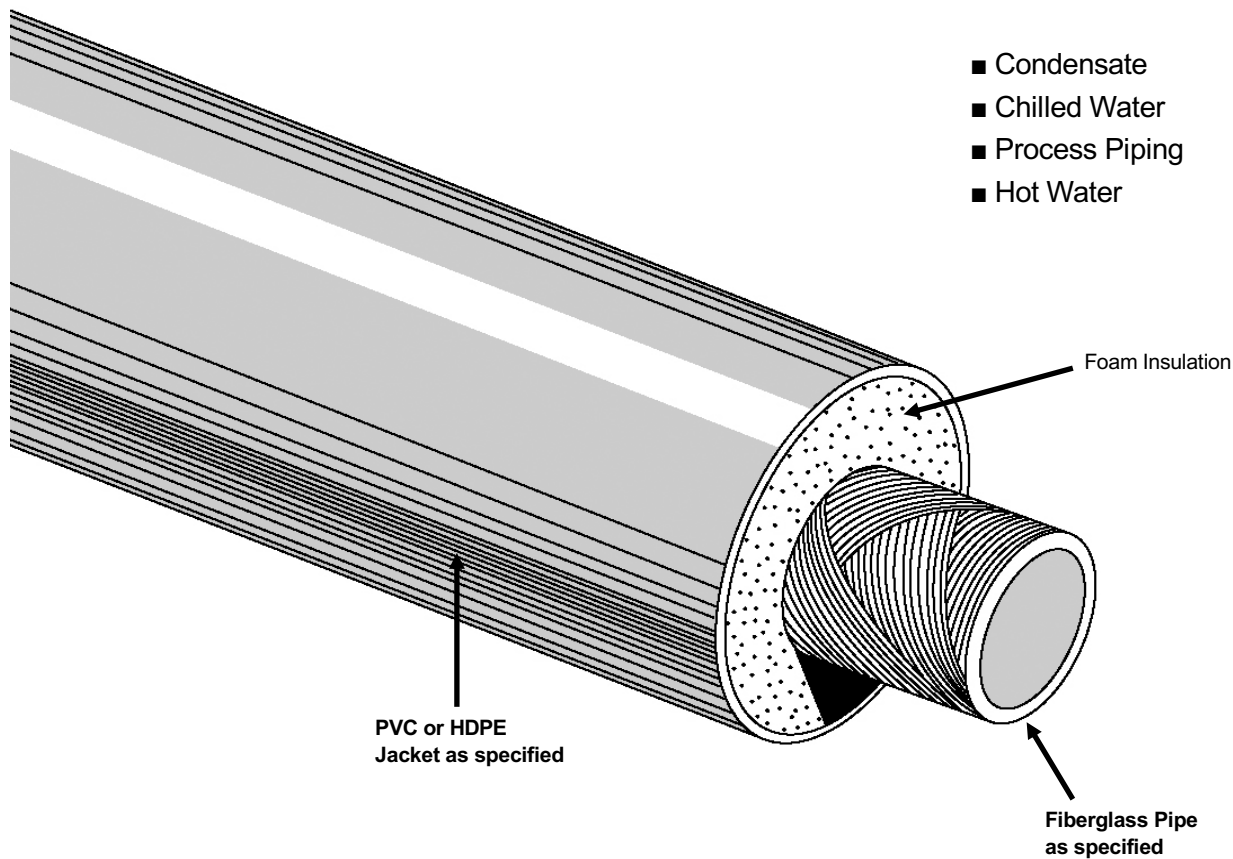

Rovanco's FRP System is designed for applications of pumped condensate, hot water, chill water, process line, etc. Carrier pipe insulation is either a polyurethane or polyisocyanurate high quality foam, combined with a durable PVC jacket supplied in 20' random lengths, means an economical, high-quality system.

Rovanco's FRP System is available with each end sealed for moisture protection and the joints are made with an epoxy resin.

Fittings are also made with an epoxy resin and thrust blocked in the field by the installer.

FRP comes complete with joint adhesive and fittings as required for the installation.

To find out more about Rovanco's FRP System, you can visit our factory, phone us (815) 741-6700, fax us (815) 741-4229, visit our website at [www.rovanco.com](http://www.rovanco.com) or e-mail us at [marketing@rovanco.com](mailto:marketing@rovanco.com).

*This is a generic product datasheet and is not intended for submittal use.*

# SPECIFICATION DATA SHEET

## Fiberglass Piping System for Underground Condensate, Chilled Water, Process Piping and Hot Water Applications

### Carrier Pipe:

**Green Thread HP** 16 bar filament wound fiberglass reinforced epoxy, bell and spigot, designed to withstand 230°F. ID of pipe shall contain a resin-rich liner. All 1" through 42 pipe to be in 20' random lengths. Pipe to be in conformance with ASTM D-2996.

**Red Thread HP** 16 pipe filament would fiberglass reinforced epoxy, bell and spigot, designed to withstand 210°F. ID of pipe to be 20' random lengths. Pipe to be in conformance with ASTM D-2996.

**Red Thread IIA (for fuels)** – Pipe is manufactured by filament winding process using amine-cured epoxy thermosetting resin to impregnate strands of continuous glass filaments with a resin-rich interior surface. The operating pressure of the pipe is up to 250 psig (17.2 bar) with continuous operating temperature to 150°F (66°C). Red Thread IIA is Listed with UL Standard 971-2004 for non-metallic underground piping for motor vehicle, high blend, concentrated and aviation and marine fuels. ID of pipe to be 20' random lengths. Pipe to be in conformance with ASTM D-2996.

### Polyurethane Insulation:

Insulation shall be a polyurethane foam injected with one shot into the annular space between carrier pipe and jacket. Insulation shall be rigid, minimum 90% closed cell polyurethane with a minimum 2.0 lbs per foot<sup>3</sup> density, compressive strength of 30 psi @ 75°F and a thermal conductivity K factor no higher than 0.180 @ 75°F per ASTM C-518. Maximum operating temperature of urethane foam shall not exceed 250°F.

### Polyisocyanurate Insulation:

Insulation shall be a polyisocyanurate foam injected with one shot into the annular space between carrier pipe and jacket. Insulation shall be rigid, >90% closed cell polyisocyanurate with a minimum 2.0 lbs per foot<sup>3</sup> density, compressive strength of 30 psi @ 75°F, a thermal conductivity K factor no higher than 0.121 @ 75°F per ASTM C-518 and an E84 25/50 passive fire resistance rating. Maximum continuous operating temperature of polyisocyanurate foam shall not exceed 300°F. Also available in a 400°.

### Jacketing Material:

High impact, seamless Polyvinylchloride (PVC) Class 12454-B compound conforming to ASTM 1784, Type 1, Grade 1, through 16" diameter. Jacket can also be high density polyethylene (HDPE) conforming to ASTM D3350. Type III, Category 5, Class C and Grade P23/P34. With a minimum of 2% by weight of carbon black. Minimum thickness is 175 mils. No FRP overwrap or sprayed jacketing will be allowed. Minimum jacket thickness shall be in accordance with Table 1.

### Fittings:

All fittings will be filament wound, heavy duty, bell & spigot type with a .020 interior liner in conformance with MIL-P28584A and MIL-P22245A. 90° elbows will be long radius only. All fittings will be un-insulated to permit proper thrust blocking.

### Joining Method:

Pipe and Fittings will be joined using a thermosetting epoxy resin. Mechanical Joints or O-Ring seal will not be allowed. Coupling joints and fittings will be un-insulated.

Table 1:

Nominal Pipe Size In Inches	Min. Foam Thickness in Inches for PVC/HDPE	Jacket Size In Inches	PVC Jacket Thickness in Mils	HDPE Jacket Thickness in Mils
1 ½	1.05/2.15	4	60	200
2	1.81/1.91	6	70	200
2 ½	1.56/1.66	6	70	200
3	1.25/1.35	6	70	200
4	1.75/1.57	8	80	175
6	1.68/1.51	10	100	175
8	1.68/1.72	12	120	175
10	1.64/1.48	14	140	175
12	1.45/1.38	16	168	175

\* Larger sizes are also available upon request.

### End Seal:

Each length of pre-insulated pipe will be fitted with a watertight mastic end seal at jacket and pipe surfaces. All field cuts will be sealed with a field applied end seal. For non-insulated joints, the end seals shall have a letter of certification from an independent Testing Laboratory that they have been tested and proved watertight under the following test criteria:

### Casing and End Seal testing Certification:

Test and certification procedure shall demonstrate that casing, factory and field applied end seal are capable of resisting penetration of water into the casing and insulation at 20 feet of head pressure, measured above the highest point of the test sample, subjected over the entire surface of an 8 foot casing test sample for not less than 48 hours.

### Anchors:

FRP pipe should be joined to steel systems with flanges. All steel systems should be anchored within five feet of connection point to eliminate any thrust, stress, or torque from the steel pipe being transferred to the FRP. Steel flanges should be 150# flat faced.

### Thrust Blocks:

All changes in directions will be poured in concrete thrust blocks to provide anchor points and to direct expansion and contraction.

### Backfill:

Should be tampered compactly in place so as to assure a stable surface. No rock shall be used in the first foot of backfill. 24 inches, top of pipe to grade, of compacted fill shall meet H-20 Highway loading.

### Manufacturer's Assistance:

Rovanco will provide a field service man on-site to properly train the installing personnel in all phases of installation(if required).

### Approved Vendors:

FRP Pipe Systems by Rovanco, Joliet, Illinois or approved, ISO certified, equal. Any alternate supplier must submit their technical data to the engineer ten days prior to bid date to be approved in writing as an equal.

cc #4082024

Copyright 2024 – Rovanco's products are covered by various U.S. patents. Rovanco & Insul-8 are federally registered trademarks.

**Contact Rovanco® for the name of your local Representative**

20535 S.E. Frontage Road • Joliet, Illinois 60431 • (815) 741-6700

Website: [www.rovanco.com](http://www.rovanco.com) • E-mail: [marketing@rovanco.com](mailto:marketing@rovanco.com)

*This is a generic product datasheet and is not intended for submittal use.*