

Fiberglass Wrapped High Temp Conduit

A Class “A” Drainable, Dryable and Testable Conduit

For High Temperature Above or Below Ground Applications

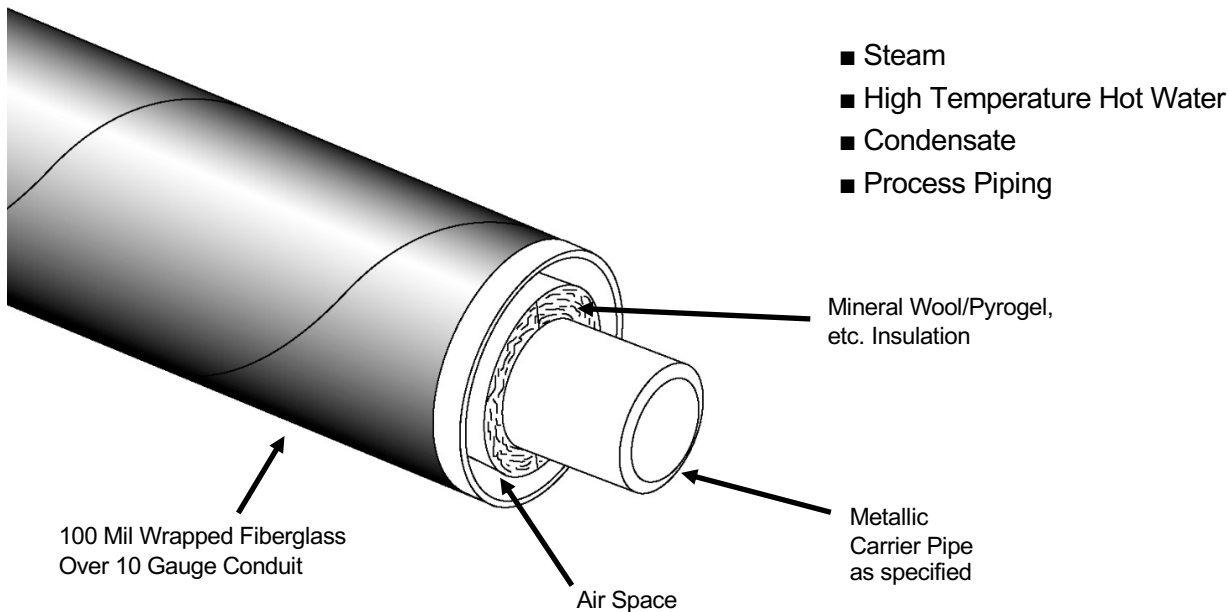

Rovanco's FRP Wrapped High Temp Conduit is designed piping systems suitable for up to 750°F applications. Mineral Wool or pyrogel, and a durable 10 gauge minimum thickness steel conduit supplied in 40' lengths, means an economical, high-quality system.

Rovanco's conduit is provided with spooled out, part numbered, cut-to-length pieces factory manufactured to field dimensions. All elbows and tees are manufactured at Rovanco's plant.

The exterior of the 10 gauge steel conduit is wrapped with 100 mils of fiberglass and designed to withstand 35,000 volt holiday test. We also have leak detection and heat trace capabilities.

The conduit comes complete with joint insulation and 2-piece steel connector bands (full rounds on 4" & 6" systems) the same thickness as the jacket with a shrink sleeve to make the installation completely watertight – the right product for applications of high pressure steam, condensate, hi-temp hot water, etc.

To find out more about Rovanco's FRP Wrapped High Temp Conduit system, you can visit our factory, phone us (815)741-6700, visit our website at www.rovanco.com or email us at marketing@rovanco.com.

Fiberglass Wrapped High Temp Conduit GUIDE SPECIFICATION

High-Temperature Pre-Insulated Conduit Systems for Steam, High-Temperature Hot Water, Condensate, Etc.

Carrier Pipe:

A53B Black Steel Pipe ERW, in pre-cut lengths. Pipe 10" and smaller shall be Schedule 40. Pipe 12" and larger shall be .375 wall. (Schedule 80 shall be used for condensate lines. Other metallic pipe available.

Insulation:

Shall be sectional Mineral Wool covered with a vinyl coated scrim with a K factor of .31 at 200° F. Sectional insulation shall be banded on pipe with stainless steel banding on 18" centers. Insulation thickness shall be as specified. Other insulations available.

Inner Pipe Supports:

All pipe shall be aligned and supported within the casing with steel supports spaced on centers approximately 10'0". The insulated inner pipe shall bear directly on the steel support. The support shall be designed as to permit drainage and free air passage. All pipe passing through supports shall be insulated. Concrete type pipe supports will not be allowed.

Outer Conduit Casing:

Outer casing shall be black steel. Casing up through 24" shall be 10 gauge. The interior surface shall be smooth to permit free moisture drainage and removability of the inner assembly. The outer casing shall be sized to provide adequate annular space between the outer surface of the insulation material and the interior surface of the casing. Exterior will be wrapped in 100 mils of fiberglass.

Outer conduit casing closures shall consist of steel suitably rust proofed and in cylindrical form with a single horizontal split and shall be field welded over adjacent units. After tests all exposed closures shall be covered in the field with a polyethylene heat shrink material with a minimum thickness of 60 mils.

Expansion loops and Elbows:

Expansion loops or expansion elbows shall be furnished and enclosed in the same type of casing as those furnished for the standard section of the piping system. They will be of a size to permit the inner pipe or pipes to move without damage to the insulation material. All expansion loops or expansion elbows shall be pre-fabricated and shipped to the job site in as few pieces as possible (manufacturers' recommendation to govern). All inner pipe loops and expansion bends shall be cold sprung in the field by the contractor as required.

Weld Fittings:

All changes in direction shall be made with bent or weld fittings. Where tee branches are smaller than the main they join, weld-o-lets may be used. All weld fittings shall be long radius and shall be the same wall thickness as adjacent piping.

Anchors:

Anchors shall be pre-fabricated onto the piping units and shall be equipped with drainage and vent openings at the top and bottom of the anchor plate. Anchor plates shall be made of 1/2" steel plate. Anchors to be galvanized.

End Seals and Gland Seals:

Terminal ends of conduit inside manholes, pits or building walls shall be equipped with end seals consisting of a steel bulkhead plate welded to the pipe conduit. Where there is an anchor within five feet of the terminal end, conduits shall be equipped with gland seals consisting of a packed stuffing box and gland follower mounted on the steel plate welded to end of conduit.

End seals and gland seals shall be made of 1/2" steel plate with drain and vent openings located diametrically opposite on the vertical center line of the mounting plate and shall be shipped to the job site with plugs in place. Terminate all conduit 2 inches beyond the inside face of building wall to protect any exposed piping insulation from damp wall condensation. All end seals and gland seals to be galvanized.

Field Tests:

The inner pipes of this system shall be tested hydrostatically to 1-1/2 times the working pressure of the line. If a leak is found, it shall be repaired and the test repeated. The outer casing shall be tested with air at 15 psig and a soap solution shall be applied to the field joints to locate leaks. If leaks occur, they shall be repaired and the test repeated. After approved by test, all field joints shall be coated by the contractor. Before backfilling, the contractor shall test the conduit coating with an electric holiday detector. Any breaks in the coating system will be repaired and the test repeated by the contractor.

Back Fill:

Should be tamped compactly in place so as to assure a stable surface. No rock should be used in the first foot of backfill. 30", top of the pipe to grade, of compacted fill shall meet the H-20 Highway loading.

Installation:

The installation shall be made in accordance with plans and specifications, and manufacturer's installation instructions. Pipe system supplier will provide an installation instructor on site to train the contractor on all phases of installation if required.

Approved Vendors:

Fiberglass Wrapped High Temp Conduit System manufactured by Rovanco, Joliet, Illinois, 815-741-6700, or approved, ISO Certified, equal. Any alternative supplier must submit their technical data to the engineer ten days prior to bid date to be approved in writing as an equal.

cc #08112023

Copyright 2023 – Rovanco's products are covered by various U.S. patents. Rovanco & Insul-8 are federally registered trademarks.

Contact Rovanco® for the name of your local Representative

20535 S.E. Frontage Road • Joliet, Illinois 60431 • (815) 741-6700

Website: www.rovanco.com • E-mail: marketing@rovanco.com

This is a generic product datasheet and is not intended for submittal use.