

Rovanco Hi-Temp Elite Systems

High Temperature Above Ground (1100°F, 600°C)

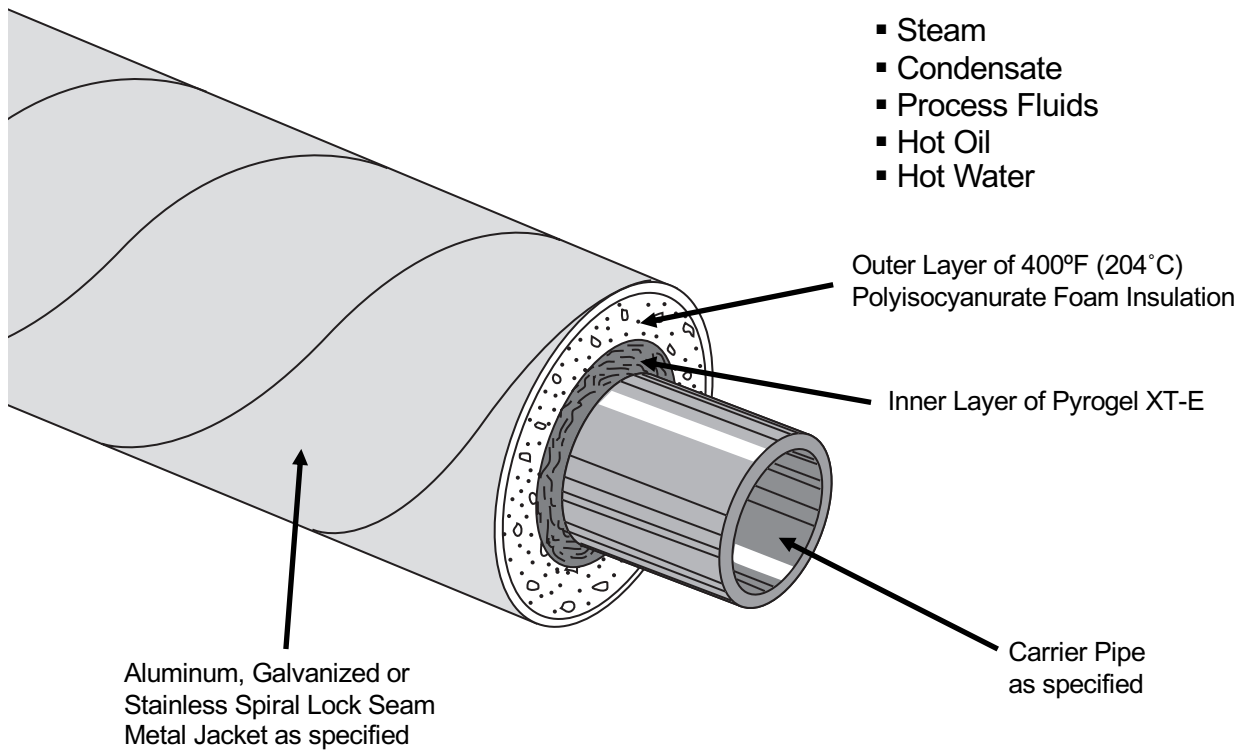

Rovanco's Hi-Temp Elite is designed for piping systems above ground suitable for indoor or outdoor applications. Non-flammable polyisocyanurate insulation and durable metal jacket supplied in 20' or 40' lengths, means an economical, high-quality system.

Rovanco's Hi-Temp Elite is provided with a spiral lock seam on a metal jacket of aluminum or galvanized steel. These jackets can be supported from the outside with maximum support spans and minimum guides. Fittings can be field insulated with material supplied by Rovanco.

The Hi-Temp Elite System comes complete with metal cover, insulation, sealant and banding to make the installation completely watertight for above grade applications.

Rovanco's Hi-Temp Elite System can be used up to 1100°F (600°C).

To find out more about Rovanco's Hi-Temp Elite System, you can visit our factory, phone us (815) 741-6700, fax us (815) 741-4229, visit our website at www.rovanco.com or e-mail us at marketing@rovanco.com.

This is a generic product datasheet and is not intended for submittal use.

SPECIFICATION FOR HI-TEMP ABOVE GROUND SYSTEM (1100°F, 600°C)

Carrier Pipe:

Shall be A-53 Grade B Schedule 40 seamless or ERW (Schedule 80 for condensate). Lengths shall be 20' or 40', random as specified. Other metallic pipes available.

Insulation:

Inner Layer

Shall be Pyrogel® XT-E as manufactured by Aspen Aerogel. Pyrogel® XT-E is a high temp insulation blanket of silica Aerogel and reinforced with a non-woven, glass-fiber batting. Sectional insulation shall be banded on pipe with aluminum banding on 18" center. Insulation thickness shall be as specified.

Outer Layer

Hi-Temp polyisocyanurate foam insulation has a K factor of .145, density of 2.5, closed cell content of 87%, compressive strength of 30 psi, and continuous service temperature of 400°F. Insulation must be capable of handling intermittent temperature spikes to 450°F. Conformance with ASTM Standard D1621, 1622, 1623, 2126, 2842, 2856, and C518-91. Completely filling the annular space between the carrier pipe and jacketing and shall be tested for voids using FLIR technology. Provide written performance certification with submittals. Also available in a 300°F polyisocyanurate foam.

Jacketing Material:

Jacket Size In Inches	Aluminum Jacket Spiral Aluminum with impact and Chemical resistance equivalent to H-14 Temper T-3003 in accordance with ASTM-B 313 specifications	Galvanized Steel Jacket Spiral Seam Galvanized Steel in accordance with ASTM A-366 ASTM A-26 G90.	Stainless Steel Jacket Spiral Seam Stainless Steel in accordance with ASTM A-366 ASTM A-26 G90.
4	22 Gauge	26 Gauge	26 Gauge
6	22 Gauge	26 Gauge	26 Gauge
8	22 Gauge	26 Gauge	26 Gauge
10	22 Gauge	26 Gauge	26 Gauge
12	22 Gauge	26 Gauge	26 Gauge
14	18 Gauge	22 Gauge	22 Gauge
16	18 Gauge	22 Gauge	22 Gauge
18	18 Gauge	22 Gauge	22 Gauge
20 & larger	18 Gauge	22 Gauge	22 Gauge

cc #04102024

Insulated Fitting and Joints:

All straight joints and fitting joint shall be insulated using material supplied by system manufacturer.

Jacket Fitting and Joint Cover:

Provide metal covers designed to fit snugly on the jacketing to provide a watertight closure. All covers shall be banded in place with 3/8" wide stainless steel straps and will be the same thickness as the jacketing.

Factory pre-fabricated and pre-insulated fittings are also available.

Anchors:

All anchors will be 1/2" thick steel plate welded to internal pipe and sealed at jacket areas per manufacturers' recommendations.

Approved Vendors:

HT Elite Systems by Rovanco, Joliet, Illinois. All other manufacturers wishing to bid on this project must be ISO Certified and provide the engineer with certified test data from either foam manufacturer or an independent testing agency that the product is capable of withstanding the service temperature continuously. The manufacturer shall obtain written approval from the engineer 10 days prior to bid date.

* Contact our home office or local representative for insulation sizing.

Copyright 2024 – Rovanco’s products are covered by various U.S. patents. Rovanco & Insul-8 are federally registered trademarks.

Contact Rovanco® for the name of your local Representative

20535 S.E. Frontage Road • Joliet, Illinois 60431 • (815) 741-6700

Website: www.rovanco.com • E-mail: marketing@rovanco.com

This is a generic product datasheet and is not intended for submittal use.