

# Rhinocoat™ ELITE High Temp Stainless Conduit

A Class “A” Drainable, Dryable and Testable Conduit

For High Temperature Above or Below Ground Applications

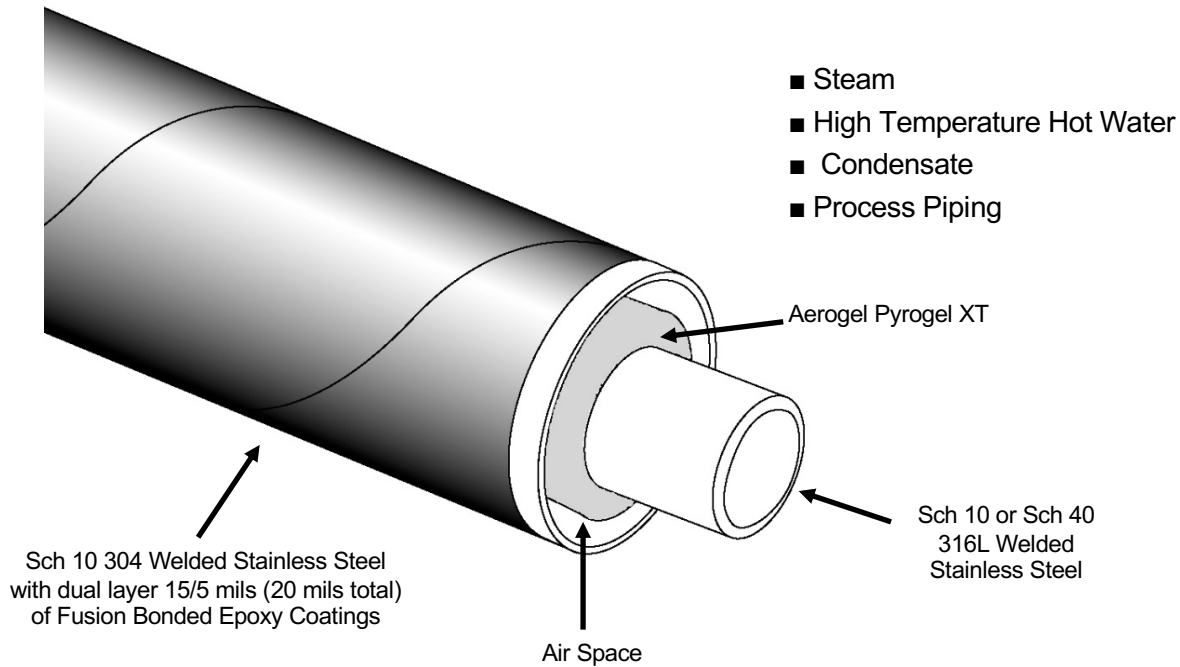

Rovanco's Rhinocoat™ Elite High Temp Stainless Conduit is designed piping systems suitable for up to 750°F applications. Pyrogel XT insulation, and a Sch 10 stainless steel conduit supplied in 20' or 40' lengths, means an economical, high-quality system.

Rovanco's conduit is provided with spooled out, part numbered, cut-to-length pieces factory manufactured to field dimensions. All elbows and tees are manufactured at Rovanco's plant.

The outer containment shall be coated with nominal 20 mil thick "state-of-the-art" Fusion Bonded Epoxy Rhinocoat™ applied in a dual 15/5 layer process.

The conduit comes complete with joint insulation and steel sleeves the same thickness as the jacket with a shrink sleeve to make the installation completely watertight – the right product for applications of high pressure steam, condensate, hi-temp hot water, etc.

To find out more about Rovanco's High Temp Stainless Conduit Elite system, you can visit our factory, phone us (815)741-6700, visit our website at [www.rovanco.com](http://www.rovanco.com), or email us at [marketing@rovanco.com](mailto:marketing@rovanco.com).

# Rhinocoat™ ELITE High Temp Stainless Conduit GUIDE SPECIFICATION

## High-Temperature Pre-Insulated Conduit Systems for Steam, High-Temperature Hot Water, Condensate, Etc.

### Carrier Pipe:

Sch 10 or Sch 40 316L Welded Stainless Steel.

### Insulation:

Shall be Pyrogel® XT as manufactured by Aspen Aerogels. Pyrogel® XT is a high temp insulation blanket formed of silica aerogel and reinforced with a non-woven, glass-fiber batting. Sectional insulation shall be banded on pipe with aluminum banding on 18" centers. Insulation thickness shall be as specified.

### Inner Pipe Supports:

All pipe shall be aligned and supported within the casing with stainless steel supports spaced on centers approximately 10' 10". The insulated inner pipe shall bear directly on the steel support. The support shall be designed as to permit drainage and free air passage. All pipe passing through supports shall be insulated. Concrete type pipe supports will not be allowed.

### Outer Conduit Casing:

Outer casing shall be Sch 10 304 Welded Stainless Steel.

The Interior surface shall be smooth to permit free moisture drainage and removability of the inner assembly. The outer casing shall be sized to provide an adequate annular space between the outer surface of the pipe material and the interior surface of the casing.

The exterior surface will be coated with a dual layer Fusion Bonded Epoxy system. The first coat will be 15 mils green finish coat. No glasswrap or filler materials shall be used in the epoxy. All exterior conduit surfaces shall be shot-blasted prior to the coating being applied. The Fusion Bonded Epoxy shall conform to three ASTM Standards: ASTM D1763, ASTM G17, ASTM D1044, ASTM D2370, ASTM G14, ASTM G8, ASTM D968, ASTM D1002, ASTM D659, ASTM D257, ASTM D1000, ASTM G53 and ASTM B117.

The second layer will be 5 mils of black or brown compatible Fusion Bonded Epoxy coating that will provide mechanical protection to the first layer. The second layer of Fusion Bonded Epoxy will be applied no later than 5 seconds after the first layer has been applied so that it securely bonds to the first layer as both layers cure. The second layer must have an impact resistance of at least 160 lbs. per square inch as per ASTM G14-72. The Fusion Bonded Epoxy coating will be applied in a total thickness of no less than 20 mils. The coating system will be equal to Rovanco Piping Systems – Rhinocoat™. No asphalt, coal tar coating, FRP casing or any other type will be allowed.

Outer casing closures shall consist of 10 gauge steel suitably rustproofed and in cylindrical form with a single horizontal split and shall be field welded over adjacent units. After tests all exposed closures shall be covered in the field with a polyurethane heat shrink material with a minimum thickness of 60 mils.

### Expansion loops and Elbows:

Expansion loops or expansion elbows shall be furnished and enclosed in the same type of casing as those furnished for the standard section of the piping system. They will be of a size to permit the inner pipe or pipes to move without damage to the insulation material. All expansion loops or expansion elbows shall be pre-fabricated and shipped to the job site in as few pieces as possible (manufacturers' recommendation to govern). All inner pipe loops and expansion bends shall be cold sprung in the field by the contractor as required.

### Weld Fittings:

All changes in direction shall be made with bent or weld fittings. Where tee branches are smaller than the main they join, weld-o-lets may be used. All inner fittings shall be long radius and shall be the same wall thickness as adjacent piping.

### Anchors:

Anchors shall be pre-fabricated onto the piping units and shall be equipped with drainage and vent openings at the top and bottom of the anchor plate. Anchor plates shall be made of ½" stainless steel plate.

### End Seals and Gland Seals:

Terminal ends of conduit inside manholes, pits or buildings walls shall be equipped with end seals consisting of a stainless steel bulkhead plate welded to the pipe conduit. Where there is an anchor within five feet of the terminal end, conduits shall be equipped with gland seals consisting of a packed stuffing box and gland follower mounted on the steel plate welded to end of conduit.

End seals and gland seals shall be made of ½" stainless steel plate with drain and vent openings located diametrically opposite on the vertical center line of the mounting plate and shall be shipped to the job site with plugs in place. Terminate all conduit 2 inches beyond the inside face of building wall to protect any exposed piping insulation from damp wall condensation

### Leak Detection (Optional):

Rovanco-Water Wire-HT is designed to detect and locate water collecting up to 450° F design temp. A leak will only be detected with a puddle of water.

### Field Tests:

The inner pipes of this system shall be tested hydrostatically to 1-1/2 times the working pressure of the line. If a leak is found, it shall be repaired and the test repeated. The outer casing shall be tested with air at 15 psig and a soap solution shall be applied to the field joints to locate leaks. If leaks occur, they shall be repaired and the test repeated. After approved by test, all field joints shall be coated by the contractor. Before backfilling, the contractor shall test the conduit coating with an electric holiday detector. Any breaks in the coating system will be repaired and the test repeated by the contractor.

### Back Fill:

Should be tamped compactly in place so as to assure a stable surface. No rock should be used in the first foot of backfill. 24", top of the pipe to grade, of compacted fill shall meet the H-20 Highway loading.

### Installation:

The installation shall be made in accordance with plans and specifications, and manufacturer's installation instructions. Pipe system supplier will provide an installation instructor on site to train the contractor on all phases of installation if required.

### Approved Vendors:

Rhinocoat™ High Temp Stainless Conduit Elite System manufactured by Rovanco, Joliet, Illinois, 815-741-6700, or approved, ISO Certified, equal. Any alternative supplier must submit their technical data to the engineer ten days prior to bid date to be approved in writing as an equal.

cc #01192024

Copyright 2023 – Rovanco's products are covered by various U.S. patents. Rovanco & Insul-8 are federally registered trademarks.

## Contact Rovanco® for the name of your local Representative

20535 S.E. Frontage Road • Joliet, Illinois 60431 • (815) 741-6700

Website: [www.rovanco.com](http://www.rovanco.com) • E-mail: [marketing@rovanco.com](mailto:marketing@rovanco.com)

*This is a generic product datasheet and is not intended for submittal use.*