

Rhinocoat™ Steel Containment Pipe

For Above or Below Ground Applications

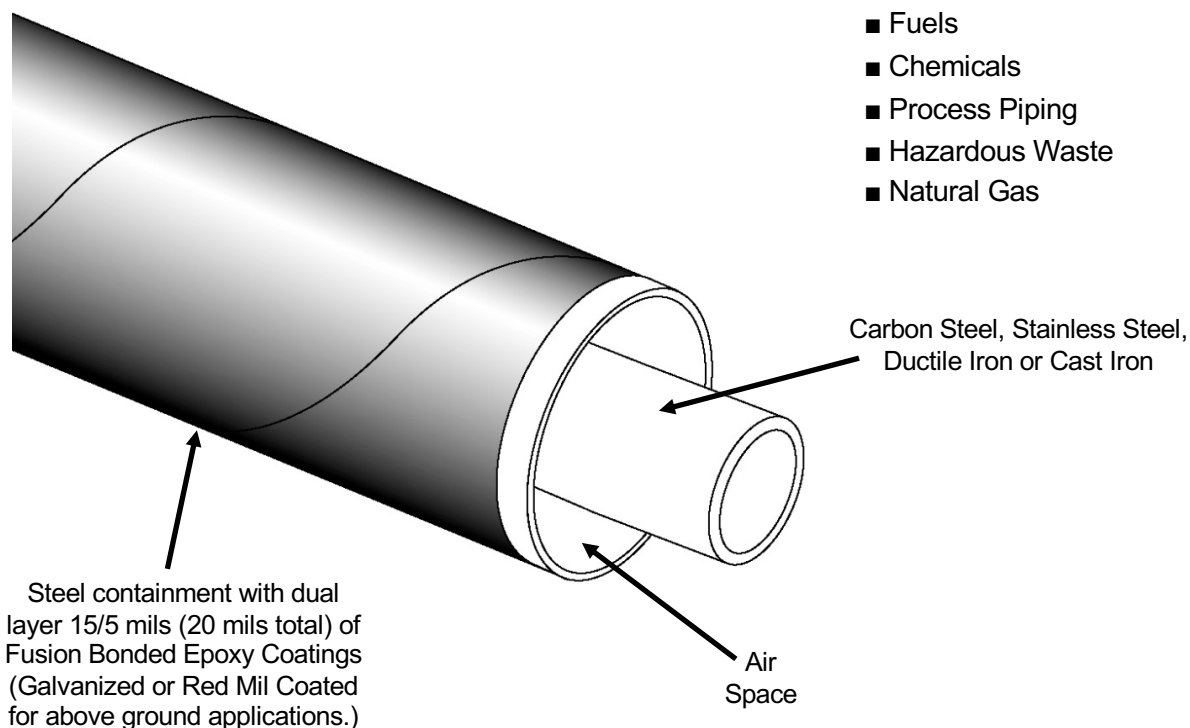

Rovanco's Containment Conduit is designed for piping systems with durable 10 gauge minimum thickness metal conduit. Supplied in 20' or 40' lengths, means an economical, high-quality system.

It is provided with part numbered spooled out, cut-to-length pieces factory manufactured to field dimensions. All elbows and tees are manufactured at Rovanco's plant, or as a Rovanco Quick-Fit field fabricated system.

The outer containment is coated with nominal 20 mil thick "state-of-the-art" Fusion Bonded Epoxy Rhinocoat™ applied in a dual 15/5 layer process.

For above ground outside applications, the steel casing can have a hot dipped galvanized or red mil coating

The containment comes complete with steel sleeves the same thickness as the conduit, and shrink sleeves and coatings to make the installation completely watertight – the right product for applications of fuels, chemicals, etc.

To find out more about Rovanco's containment system, you can visit our factory, phone us (815) 741-6700, fax us (815) 741-4229, visit our website at www.rovanco.com or e-mail us at marketing@rovanco.com.

This is a generic product datasheet and is not intended for submittal use.

GUIDE SPECIFICATION

Carrier Pipe:

A53B Black Steel pipe, Seamless or ERW, in pre-cut lengths. Pipe 10" and smaller shall be Schedule 40. Pipe 12" and larger shall be .375 wall. (Schedule 80). Other piping materials and thicknesses also available. Also available with Stainless Steel, Ductile Iron or Cast Iron inner carrier pipes

Inner Pipe Supports:

All pipe shall be aligned and supported within the casing with centering supports spaced on approximately 10'0". The inner pipe shall bear directly on the support. The support shall be designed as to permit drainage and free air passage. Concrete type pipe supports will not be allowed.

Outer Containment Casing:

Outer casing shall be black steel. Casing up through 24" shall be 10 gauge. Casing 26" and larger shall be 6 gauge. Other thickness are also available.

The Interior surface shall be smooth to permit free moisture drainage and removability of the inner assembly. The outer casing shall be sized to provide an adequate annular space between the outer surface of the pipe material and the interior surface of the casing.

The exterior surface will be coated with a dual layer Fusion Bonded Epoxy system. The first coat will be 15 mils green finish coat. No glasswrap or filler materials shall be used in the epoxy. All exterior conduit surfaces shall be shot-blasted prior to the coating being applied. The Fusion Bonded Epoxy shall conform to the ASTM Standards: ASTM D1763, ASTM G17, ASTM D1044, ASTM D2370, ASTM G14, ASTM G8, ASTM D968, ASTM D1002, ASTM D659, ASTM D257, ASTM D1000, ASTM G53 and ASTM B117.

The second layer will be 5 mils of black or brown compatible Fusion Bonded Epoxy coating that will provide mechanical protection to the first layer. The second layer of Fusion Bonded Epoxy will be applied no later than 5 seconds after the first layer has been applied so that it securely bonds to the first layer as both layers cure. The second layer must have an impact resistance of at least 160 lbs. per square inch as per ASTM G14-72. The Fusion Bonded Epoxy coating will be applied in a total thickness of no less than 20 mils. The coating system will be equal to Rovanco Piping Systems – Rhinocoat™. No asphalt, coal tar coating, FRP casing or any other type will be allowed.

Outer casing closures shall consist of 10 gauge steel suitably rustproofed and in cylindrical form with a single horizontal split and shall be field welded over adjacent units. After tests all exposed closures shall be covered in the field with a polyurethane heat shrink material with a minimum thickness of 60 mils.

For above ground outside applications, the steel casing, fitting covers and closure joints can be hot dipped galvanized or red mill coated.

Weld Fittings:

All changes in direction shall be made with bent or weld fittings. Where tee branches are smaller than the mains they join, weld-o-lets may be used. All fittings shall be the same wall thickness as adjacent piping. Fittings can be factory pre-fabricated or field fabricated Quick-Fit.

Anchor:

Anchors shall be pre-fabricated onto the piping units and shall be equipped with drainage and vent openings at the top and bottom of the anchor plate. Anchor plates shall be made of 1/2" steel plate.

End Seal:

Terminal ends inside manholes, pits, or building walls shall be equipped with end seals consisting of a steel bulkhead plate welded to the pipe conduit.

End seals shall be made of a 1/2" steel plate with drain or vent openings located diametrically opposite on the vertical center line of the mounting plate and shall be shipped to the jobsite with plugs in place. Terminate containment 2 inches beyond the inside face of building walls to protect any exposed piping from damp wall condensation.

Field Tests:

The inner pipe of the system shall be tested hydrostatically to 1-1/2 times the working pressure of the line. If a leak is found, it shall be repaired and the test repeated. The outer casing shall be tested with air at 15 psig and a soap solution shall be applied to the field joints to locate leaks. If leaks occur, they shall be repaired and the test repeated. After approved by test, all field joints shall be coated by the contractor. Before backfilling, the contractor shall test the containment coating with an electric holiday detector. Any breaks in the coating system will be repaired and the test repeated by the contractor.

Backfill:

Should be tampered compactly in place so as to assure a stable surface. No rock shall be used in the first foot of backfill. 24 inches, top of pipe to grade, of compacted fill shall meet H-20 Highway loading.

Installation:

The installation shall be made in accordance with plans and specifications, and manufacturers installation instructions. Manufacturer will provide a field service instructor on-site prior to fabrication of the piping to confirm routing, anchoring, support, and termination details. The field serviceman will also train the contractor in all phases of installation.

Approved Vendors:

Steel Containment System by Rovanco, Joliet, Illinois or approved, ISO Certified, equal. Any alternate supplier must submit their technical data to the engineer ten days prior to bid date to be approved in writing as an equal.

cc #06132023

Copyright 2023 – Rovanco's products are covered by various U.S. patents. Rovanco & Insul-8 are federally registered trademarks.

Contact Rovanco® for the name of your local Representative

20535 S.E. Frontage Road • Joliet, Illinois 60431 • (815) 741-6700

Website: www.rovanco.com • E-mail: marketing@rovanco.com

This is a generic product datasheet and is not intended for submittal use.